

ROUTINE

MWO effective date is 30 June 2005 and completion date is 01 October 2006.

MWO 9-2330-390-25-1

MODIFICATION WORK ORDER

MODIFICATION OF M1022A1 DOLLY SET POSITIONING TUBE REINFORCEMENT

Headquarters, Department of the Army, Washington, D.C.

17 October 2005

REPORTING OF ERRORS AND RECOMMENDING IMPROVEMENTS

You can help improve this publication. If you find any mistakes or if you know of a way to improve the procedures, please let us know. Submit your DA Form 2028 (Recommended Changes to Equipment Technical Publications), through the Internet, on the Army Electronic Product Support (AEPS) website. The Internet address is <https://aeprs.ria.army.mil>. The DA Form 2028 is located under the Public Applications section in the AEPS Public Home Page. Fill out the form and click on SUBMIT. Using this form on the AEPS will enable us to respond quicker to your comments and better manage the DA Form 2028 program. You may also mail, fax or E-mail your letter or DA Form 2028 direct to: AMSTA-LC-LMIT / TECH PUBS, TACOM-RI, 1 Rock Island Arsenal, Rock Island, IL 61299-7630. The email address is TACOM-TECH-PUBS@ria.army.mil. The fax number is DSN 793-0726 or Commercial (309) 782-0726.

APPROVED FOR PUBLIC RELEASE; DISTRIBUTION IS UNLIMITED.

1. PURPOSE.

This modification provides reinforcement for the vertical positioning tubes during all operations.

2. PRIORITY.

This modification is classified as ROUTINE.

3. END ITEM TO BE MODIFIED.

NOTE

Application will be controlled/determined by PMLTV / PM Trailers based on Approved DCSOPS distribution plans/funding streams for M1022A1.

NOMENCLATURE	NSN	PART	CAGEC	MODEL
Dolly Set: Lift, Transportable Shelter, 7-1/2 ton	2330-01-378-9997			M1022A1

Vehicle National Stock Number (NSN) will not change as a result of this MWO.

4. MODULE (S) TO BE MODIFIED.

Not applicable

5. PART (S) TO BE MODIFIED.

NOMENCLATURE	NSN	PART NO.	CAGEC
Frame Section, Structural			
* Front	2510014262443	8D00107-1	21439
* Rear	2510013935087	8D00141-1	21439
Frame Section, Structural			
* Front	2510013935868	8D00106-1	21439
* Rear	2510013935744	8D00140-1	21439

6. APPLICATION.

- a. Time Compliance Schedule: The effective date of this MWO is 30 June 2005 and its completion date is 01 October 2006.
- b. The Lowest level of Maintenance authorized to apply the MWO is Field Support (FS) maintenance.
- c. Work force and man-hour requirements for application of the MWO to a single unit, end item, or system:

REQUIREMENTS

DESCRIPTION	WORK FORCE/SKILLS	MAN-HOURS
Detaching Front and Rear Dollies	Operational	0.5
Removal of Structural Frame Sections		
*Front	Operational / Mechanic	1.5
*Rear	Operational / Mechanic	1.5
Assembly of Modified Frame Sections		
* Front	Operational / Mechanic	1.0
* Rear	Operational / Mechanic	1.0
Installation of Structural Frame Sections		
* Front	Operational / Mechanic	2.0
* Rear	Operational / Mechanic	2.0
Placing Dolly into Transport or Travel Mode	Operational	0.5
Total man-hours required for a single application of this MWO		10.0

7. TECHNICAL PUBLICATIONS AFFECTED/CHANGED AS A RESULT OF THIS MWO.

Technical Publication

Date

TM 9-2330-390-14&P C4

01 Nov 00

8. MWO KITS, PARTS AND THEIR DISPOSITION.

- a. The following kit is required to accomplish this modification. The security classification of this kit is unclassified. Shipping data is: weight 1120.6 lbs;

NOMENCLATURE	NSN	CAGEC	PART
Positioning Tube Reinforcement Kit	2510-01-525-9947	19207	57K4755

- b. Positioning Tube Reinforcement Kit component parts are listed below. The listing is used to inventory the kit for completeness. Refer to Figures 1A and 1B for a graphical depiction of each component.

ITEM	NOMENCLATURE	RETAILER	PART NO.	QTY.
19	Beam – Rear, Bottom	Fabricated	12501507	1
20	Beam – Front, Bottom	Fabricated	12501504	1
21	Beam – Rear, Top	Fabricated	12501508	1
22	Bolt – 7 x ½ UNC, Hex	McMaster Carr	12501533	4
23	Bushing – Steel, Shoulder	Fabricated	12501523	8
24	Nut – ½ UNC, Locking	McMaster Carr	12501532	4
25	Shim – Position Cylinder	Fabricated	12501516	4
26	Bolt – ¼ UNC, Flat Head	McMaster Carr	12501538	12
27	Assembly-Cable Lanyard	Fabricated	12501535	4

MWO 9-2330-390-25-1

28	Beam – Front, Top	Fabricated	12501505	1
29	Pin – 1 x 7, Clevis	ITW	12501531	4
30	Pin – Cotter, Hairpin	McMaster Carr	12501530	4
31	Spacer	McMaster Carr	12501539	4
33	Tube – Lower Vertical	Fabricated	12501509	4
34	Tube – Upper Vertical (L)	Fabricated	12501510	2
35	Tube – Upper Vertical (R)	Fabricated	12501511	2
91	Plate, Instruction	NSN 9905-00-858-5682	10930014	1
92	Plate, Instruction	NSN 9905-01-395-2089	8D00062-20	2
93	Plate, Instruction	NSN 9905-01-395-4077	8D00062-17	2
94	Plate, Instruction	NSN 9905-01-395-2088	8D00062-15	1
95	Pin - Chase	Fabricated	12501540	2

c. Bulk and Expendable Material.

NOMENCLATURE	NSN	CAGEC	PART	QTY.
Tape: Duct 2”	5640-00-103-2254	39428	1791K70	A/R
Tape: Pressure Sensitive Adhesive 2”	7510-00-473-9513	81349	MIL-T-23397	A/R
TAG: Marker	9905-00-537-8954	81349	MIL-T-12755	A/R
Grease: Aircraft, WTR	9150-01-262-3358	81349	MIL-G-81322	A/R
Solvent: Dry Cleaning, Type II	6850-00-281-1985	81348	P-D-680	A/R
Fluid: Hydraulic	9150-00-223-4134	81349	MIL-H-5606	A/R
Rag: Wiping	7920-00-205-1711	64067	7920-00-205-1711	A/R

d. Parts Disposition. All parts not used during installation will be returned to stock for disposition in accordance with AR 725-50.

9. SPECIAL TOOLS; TOOL KITS; JIGS; TEST, MEASUREMENT, AND DIAGNOSTIC EQUIPMENT (TMDE); AND FIXTURES REQUIRED.

a. Hand tools and tool kits necessary to apply MWO are listed:

NOMENCLATURE	NSN	CAGEC	SUPPLY CATALOG
Tool Kit, General Mechanic’s	5180-00-177-7033	50980	SC 5180-90-N26
Wrench, Twist Lock		21439	8D00136 (Provided w/ Dolly)
Drill Set, Twist	5133-00-293-0983	55719	SC 4910-95-CL-A74
Drill, Electric, Portable	5130-00-293-1849	81348	SC 4910-95-CL-A74

b. Tools necessary to apply MWO are contained in the following shop set:

NOMENCLATURE	NSN	CAGEC	SUPPLY CATALOG
Shop Equipment, Automotive Maintenance And Repair	4910-00-754-0654	19204	SC 4910-95-A74

10. MODIFICATION PROCEDURE.

WARNING

Use extreme caution when handling heavy parts. Lifting device is required when parts weigh over 50 lb (23 kg) for a single person lift, over 100 lb (45 Kg) for a two person lift, and over 150 lbs (68 kg) for a three or more person lift. Keep clear of heavy parts supported only by lifting device. Failure to follow this warning may cause serious injury or death to personnel

NOTE

- Hydraulic lines should be tagged before removal.
- Positioning cylinder ports should be plugged with masking tape or other suitable means as lines are disconnected or fittings are removed.
- A suitable container should be used to catch any draining hydraulic fluid. Ensure that all spills are properly cleaned.

a. DOLLY PREPARATION

NOTE

- Preparation procedures are the same for front and rear dollies.
1. Uncouple Dolly set from Tow vehicle
 2. From the transport or travel mode (Figure 2) perform operations needed to detach front and rear dollies (Refer to Appendix A).
 3. Place front and rear dollies into maneuvering position (Figure 3) and separate by a distance of at least 30 ft or side by side. (Refer to Appendix B, Section a).
 4. Place wooden blocks (12"x12" stock) under each end of each bottom beam and remove dolly half from maneuvering position (Refer to Appendix B, Section b). Once the set is resting on blocks, place wheel chocks under each wheel. The condition of each dolly half should resemble Figure 4.
 5. Remove from top and bottom beams all detent lanyard pins, top hooks, hanger brackets (front dolly), and toolbox (front dolly). Set aside for installation to modified structure.
 6. Remove the top and bottom beams and positioning cylinders from both the front and rear dollies (Figure 5) (Refer to Appendix C, Section a).
 7. Clean and inspect all parts (Refer to Appendix C, Section b).

b. INSTALLATION

NOTE

- Installation procedures are the same for the front and rear dollies. Figure 6 & 7 illustrates installation for the front dolly.

- **Mounting hardware must face outward to prevent interference.**
1. Attach the top and bottom beams and positioning cylinders to both the front and rear dollies (Figures 6 & 7) (Refer to Appendix C, Section b).
 2. Install both stability cables (27) to mounts provided as shown in Figure 6
 3. Install instruction plates on front dolly upper vertical tube. Position first plate (uncoupling instructions) 25” below upper beam on front upper left (hydraulic valve side) vertical tube. Position second plate (coupling instructions) ½” below the first plate. Use #4-3/16 drive screws to attach. A second set of instruction plates is provided with the kit to be similarly attached to the rear dolly half.
 4. Install hanger brackets (front dolly). Position previously removed hanger bracket on upper vertical tube (34), 8 in (15.2cm) below top beam (19 – Rear, 20 Front). Reinstall U-bolt, and two flat washers with new locknuts.
 5. Install all detent lanyards pins, top hooks and toolbox previously removed.

NOTE

- **Prior to operation of the modified Dolly set, properly check hydraulic system for leaks and bleed if needed (Refer to Appendix D).**
6. Remove wooden blocks (12”x12” stock) under each end of each bottom beam and place dolly half into maneuvering position (Figure 3) (Refer to Appendix B, Section a).
 7. Perform operations needed to return dollies to travel or transport mode.

11. CALIBRATION REQUIREMENTS.

Not applicable to this MWO

12. WEIGHT AND BALANCE DATA.

a. Additional weight (1118.2 lbs).

ITEM	NOMENCLATURE	PART NO.	WEIGHT (lbs)	QTY.
19	Beam – Rear, Bottom	12501507	158.50	1
20	Beam – Front, Bottom	12501504	165.44	1
21	Beam – Rear, Top	12501508	206.41	1
22	Bolt – 7 x ½ UNC, Hex	12501533	0.52	4
23	Bushing – Steel, Shoulder	12501523	0.25	8
24	Nut – ½ UNC, Locking	12501532	0.03	4
25	Shim – Cylinder	12501516	1.24	4
26	Bolt – ¼ UNC, Flat Head	12501538	0.02	12
27	Assembly-Cable Lanyard	12501535	1.40	4
28	Beam – Front, Top	12501505	206.41	1
29	Pin – 1 x 7, Clevis	12501531	1.70	4

MWO 9-2330-390-25-1

30	Pin – Cotter, Hairpin	12501530	0.05	4
31	Spacer – 1.0 in. ID	12501539	0.14	4
33	Tube – Lower Vertical	12501509	40.22	4
34	Tube – Upper Vertical (L)	12501510	49.54	2
35	Tube – Upper Vertical (R)	12501511	49.54	2

b. Weight Removed (994.9 lbs).

ITEM	NOMENCLATURE	PART NO.	WEIGHT (lbs)	QTY.
1	Top Beam	8D00107-1 (F) 8D00141-1 (R)	273.02	2
3	Bottom Beam	8D00106 –1 (F) 8D00140 -1 (R)	220.93	2
13	Pin – Straight, Headed	8D00060-2	1.07	4
14	Washer – Flat, 1 in.	AN960-1616	0.40	4
15	Pin - Cotter	MS24665-495	0.01	4
16	Pin - Cotter	MS24665-351	0.01	4
17	Washer – Flat, ½ in.	MS51412-8	0.03	4
18	Pin – Straight, Headed	8D00060-3	0.23	4

c. Net Weight Increase (123.3 lbs).

13. QUALITY ASSURANCE REQUIREMENTS.

- a. General. The following information is furnished to ensure the proper application of this MWO and provide clarification in regard to the adequacy of installer’s inspection methods and procedures applicable to Quality Assurance (QA). Inspection shall be IAW TM 9-2330-390-14&P, and MWO.
- b. Installer Responsibilities. The installer is responsible for following instructions in MWO 9-2330-39-25-1, and TM 9-2330-390-14&P. The installer will report Positioning Tube Reinforcement Kits received that are damaged or missing component parts so the kit supplier can be properly notified. Any discrepancies noted will be corrected before the vehicle leaves the installer’s work area. Requirements contained in this MWO shall be included in the installer’s inspection plan or quality assurance program. As a minimum, a checklist will be maintained indicating all requirements have been satisfactorily accomplished for each kit. These requirements shall not be construed as eliminating the installer’s responsibility from complete compliance with provisions of the contract and submitting to the Government products that meet all requirements of the contract.
- c. Government Verification. All QA operations, installation changes, and inspections performed by the installer are subject to Government verification at unannounced and varying intervals. Verification will consist of observations and

inspections to confirm that practices, methods, and procedures of the installer's written inspection plan are being properly applied; and that Government product inspection to confirm the quality of product offered for Government acceptance does not deviate from prescribed acceptance standards specified in TM 9-2330-390-14&P. Deviations will be brought to the attention of the installer for correction.

- d. In-process Inspection. During normal assembly operations, paragraph 10, Modification Procedure, will be used to check the installer's work. After installation is complete, the installer will correct any defects noted before the Dolly is placed in service. All Dollies modified during a production shift will be checked to ensure product quality.

14. RECORDING AND REPORTING OF THE MODIFICATION.

- a. Records and Reports. The organization responsible for MWO application will report application information as follows:
 - (1) Reporting will be accomplished by electronic means. MWO application information can be input directly into the Modification Management Information System (MMIS) over the Internet. If Internet is not available, recording will be on a 3.5-inch disk, which will be mailed to the MMIS administrator. Entry into the MMIS system is password protected. New users can register on-line at <http://208.242.67.250/mwo>. Passwords are normally approved and issued within 48 hours.
 - (2) Submission will be comprised of nine (9) data elements listed in the table below. Elements 1,2,4,6,7,8 & 9 are given for this MWO (as shown). The person reporting the MWO data, will acquire the remaining elements (3 & 5), and input all nine into MMIS.

DATA Elements

Input Data

- 1. Material Change Number (MCN)
- 2. MWO Number
- 3. Unit Identification Code (UIC) @ Battalion Level
- 4. NSN of End Item
- 5. Serial Number
- 6. USA Registration Number
- 7. Date of Application
- 8. Hours required for Application.
- 9. Software Version

- (3) For off-line reporting, the 3.5-inch disk shall be mailed to the following address:
Commander

TACOM-Warren
ATTN: AMSTA-LC-CIPWM
Warren, MI 48397-5000

- b. Marking Equipment.
 - (1) After the Positioning Tube Reinforcement Kit is installed, mark MWO under 9-2330-390-25-1 in the MWO Applied block and Date Applied in Date Block on MWO instruction plate P/N 10930014 (91).
 - (2) To install the MWO instruction plate, locate a single 0.107 inch diameter hole (#37 - drill size) on the front upper left (hydraulic valve side) vertical tube above the instruction plate (see figure 9). Use #4-3/16 drive screws to attach.

15. MATERIAL CHANGE (MC) NUMBER.

- a. The Material Change (MC) Number for this MWO is 1-05-08-0001

16. MODIFICATION IDENTIFICATION.

- a. When installed correctly, the Positioning Tube Reinforcement Kit will appear as shown in figure 7.
- b. After the Positioning Tube Reinforcement Kit is installed, the positioning tube reinforcement should be inspected for secure mounting. Any faults detected, or discrepancies noted, will be corrected before the dolly is returned to normal service.

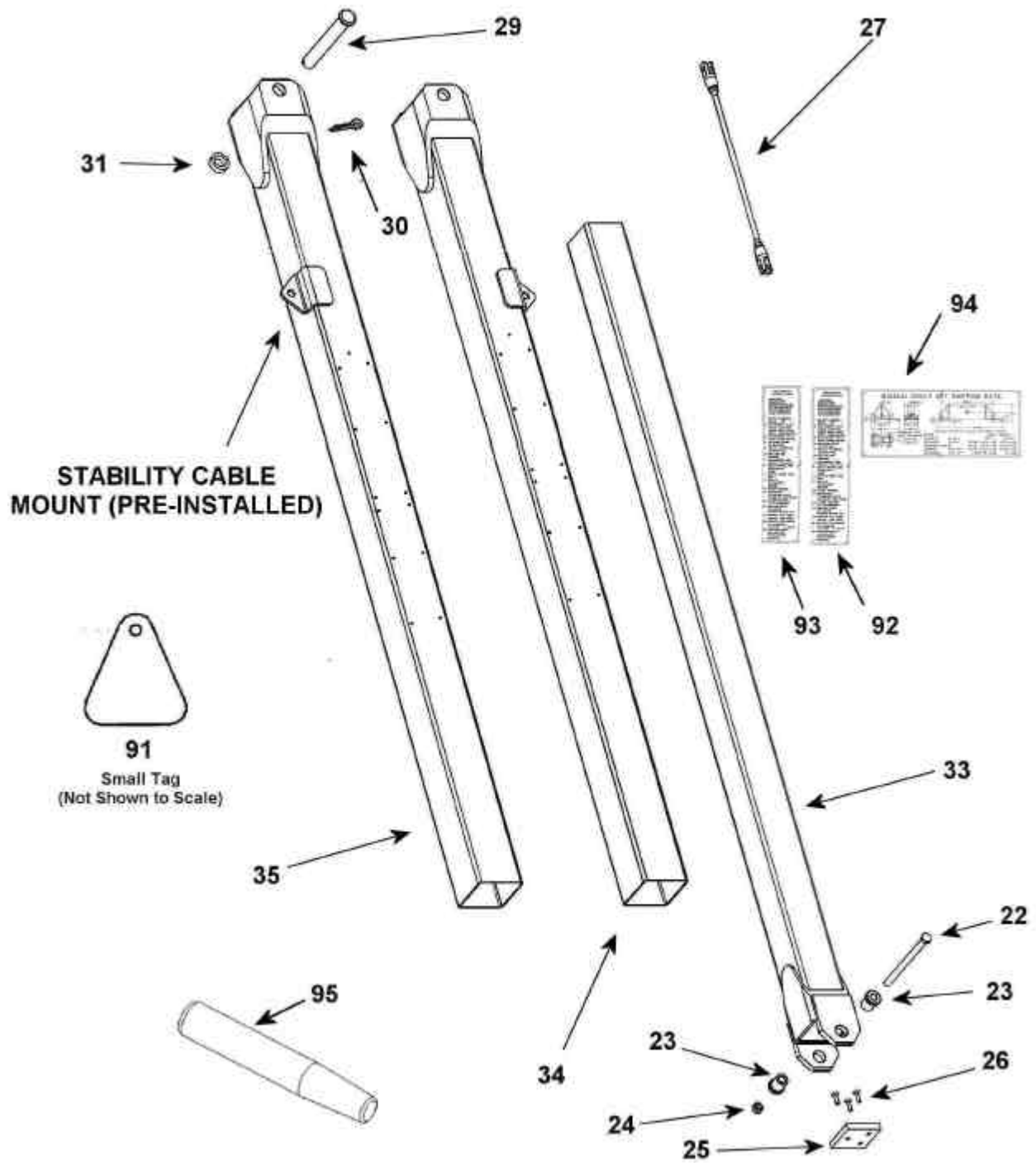

Figure 1A

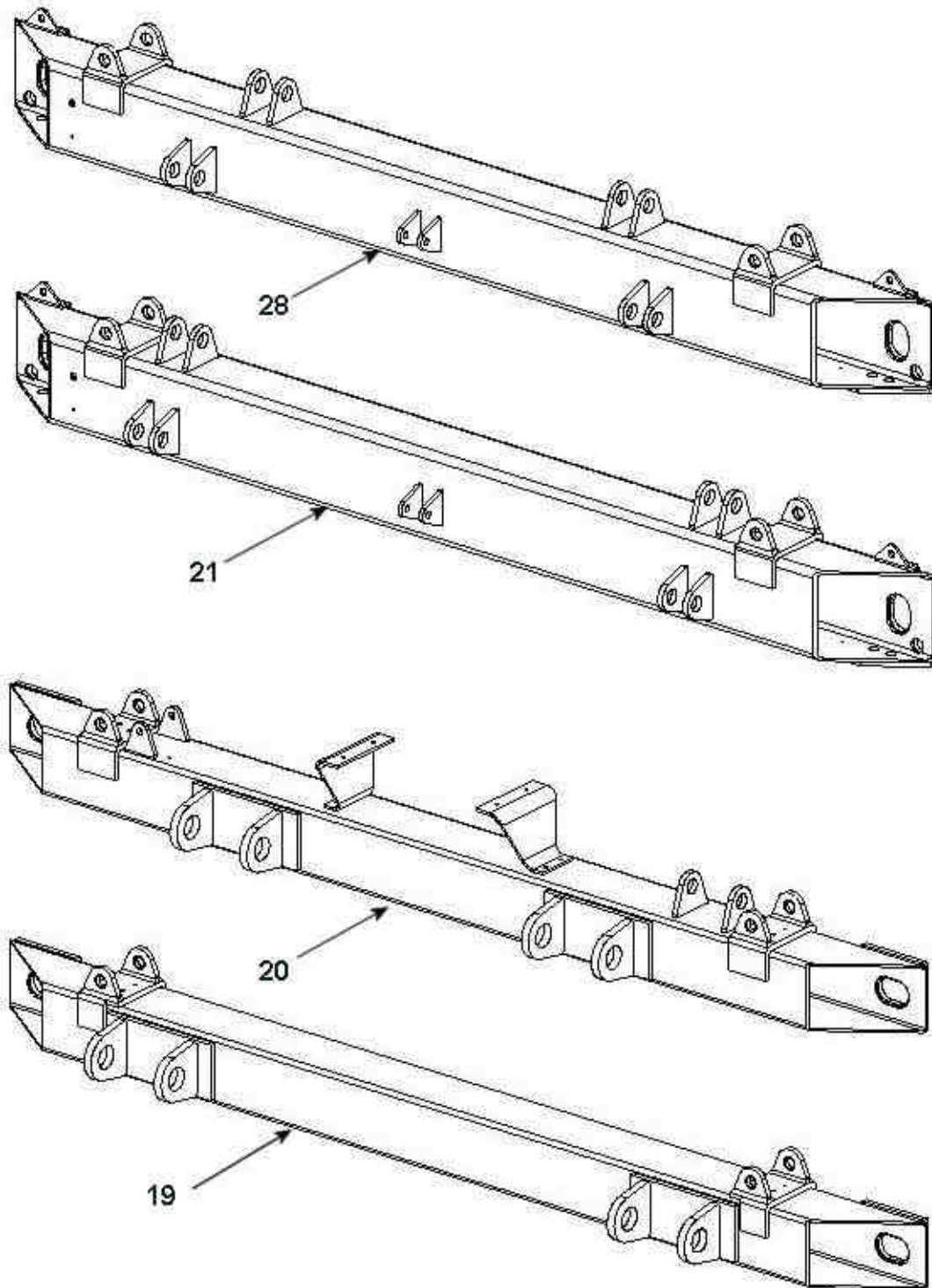
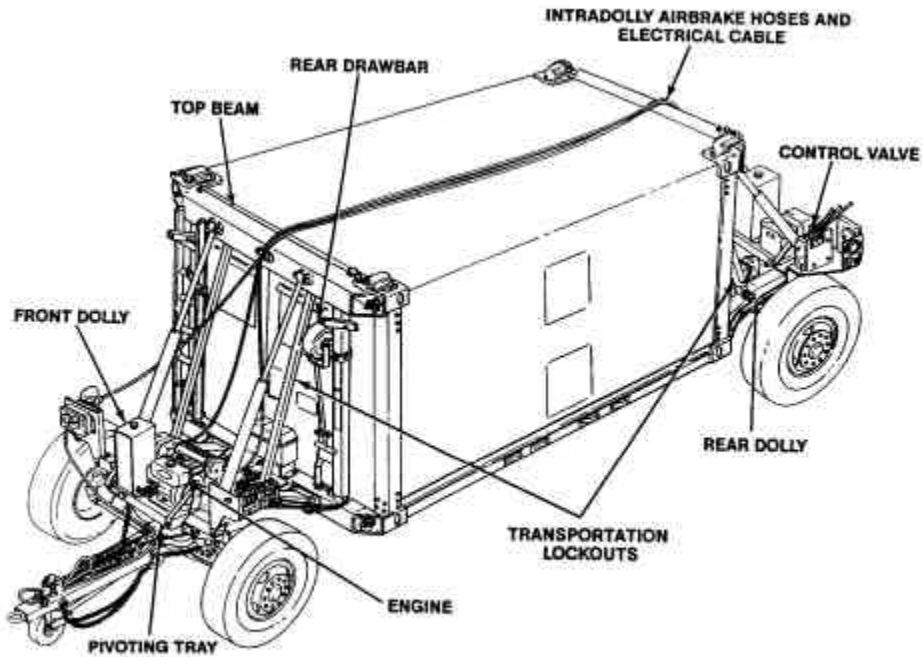

Figure 1B



TRANSPORT MODE

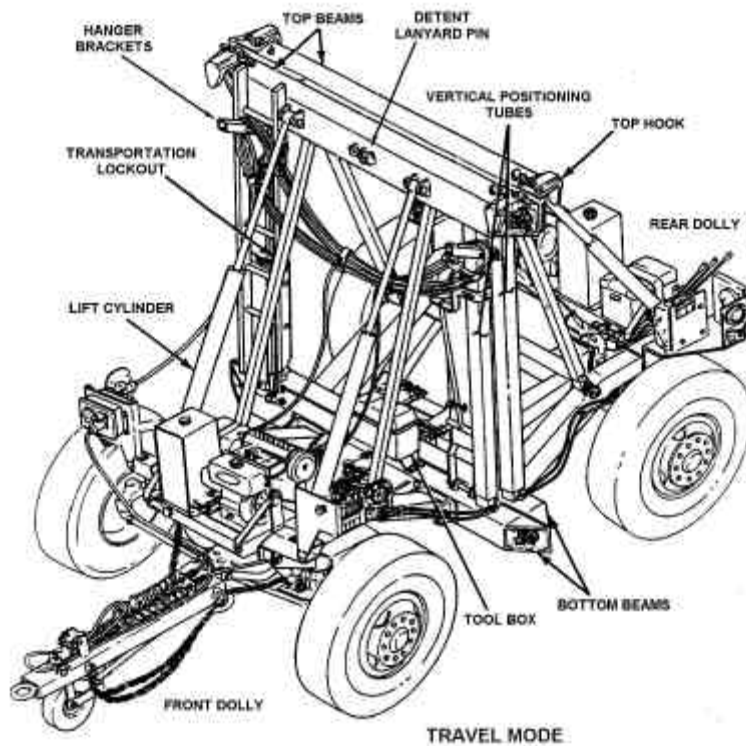

Figure 2

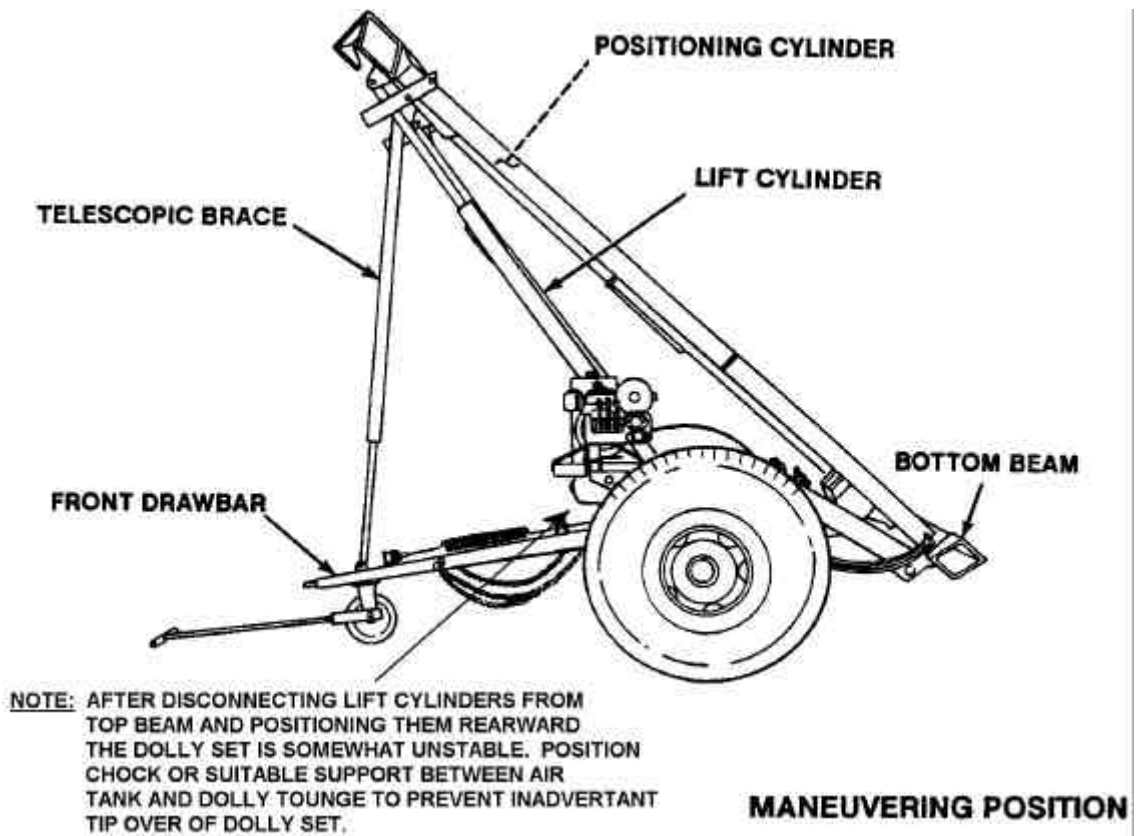

Figure 3

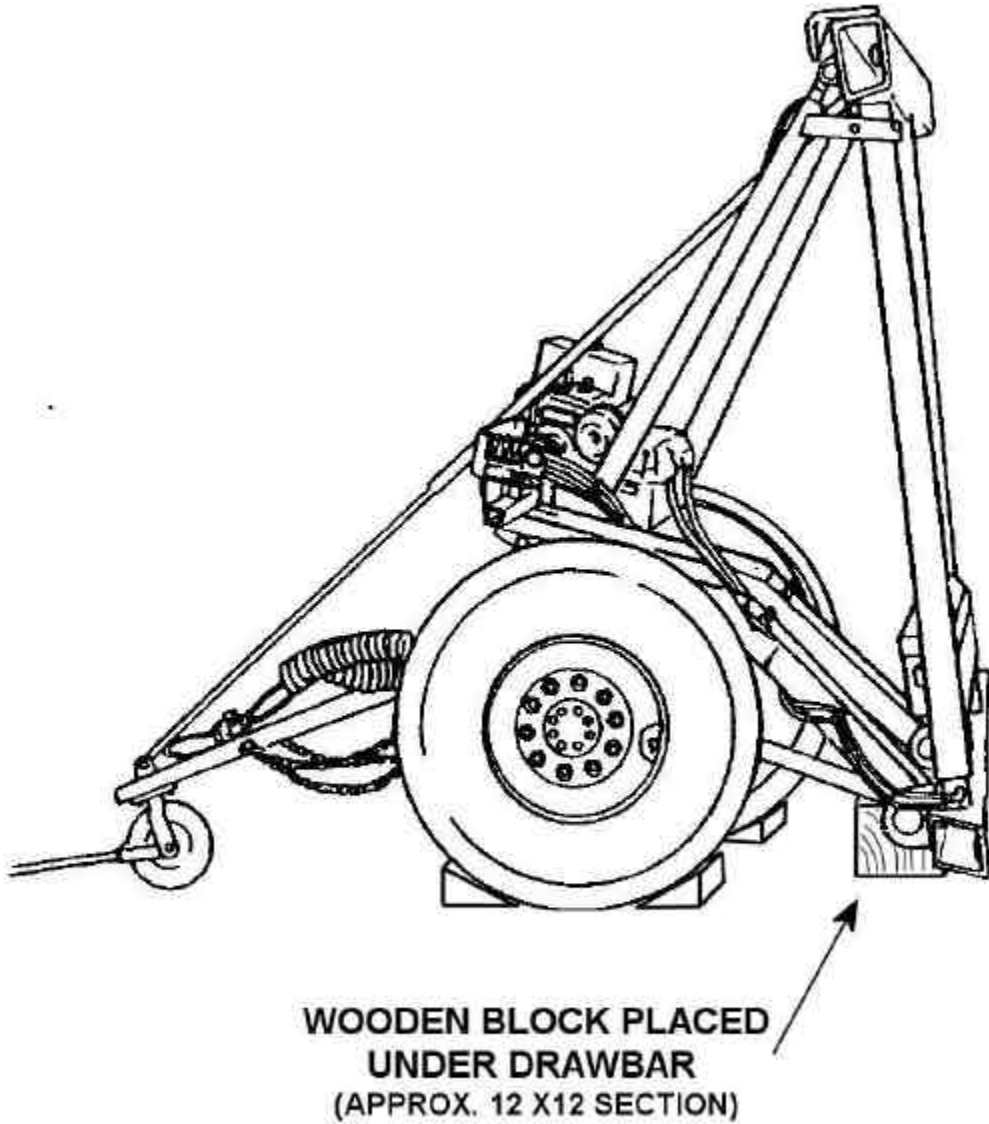

Figure 4

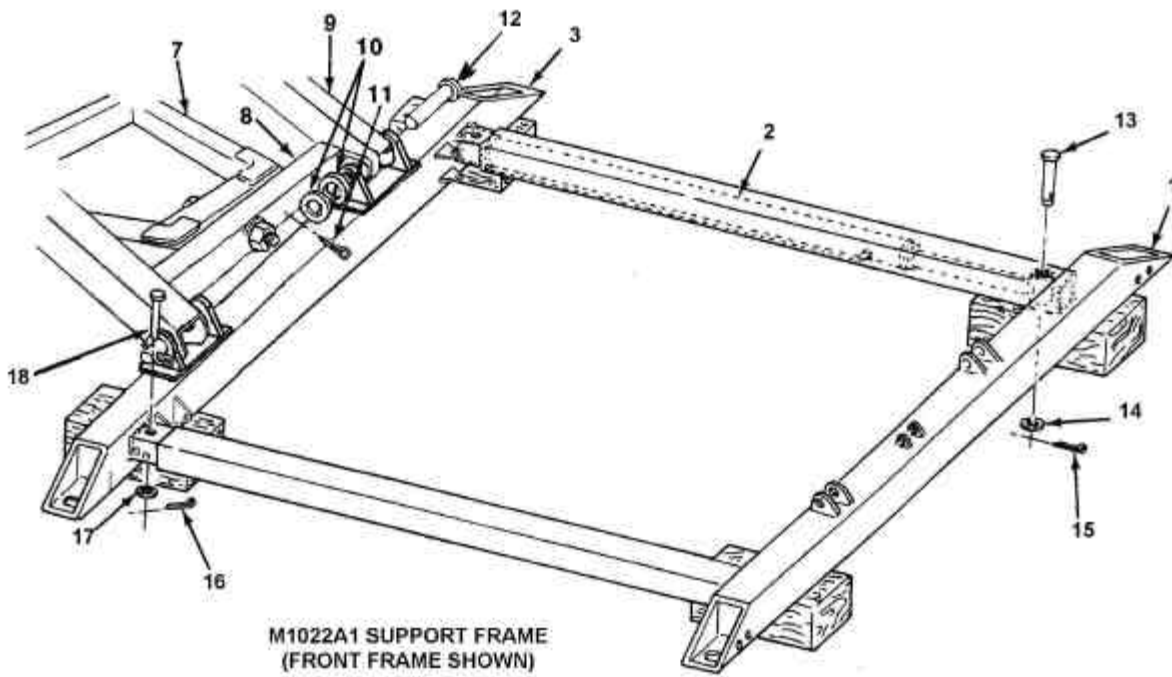

Figure 5

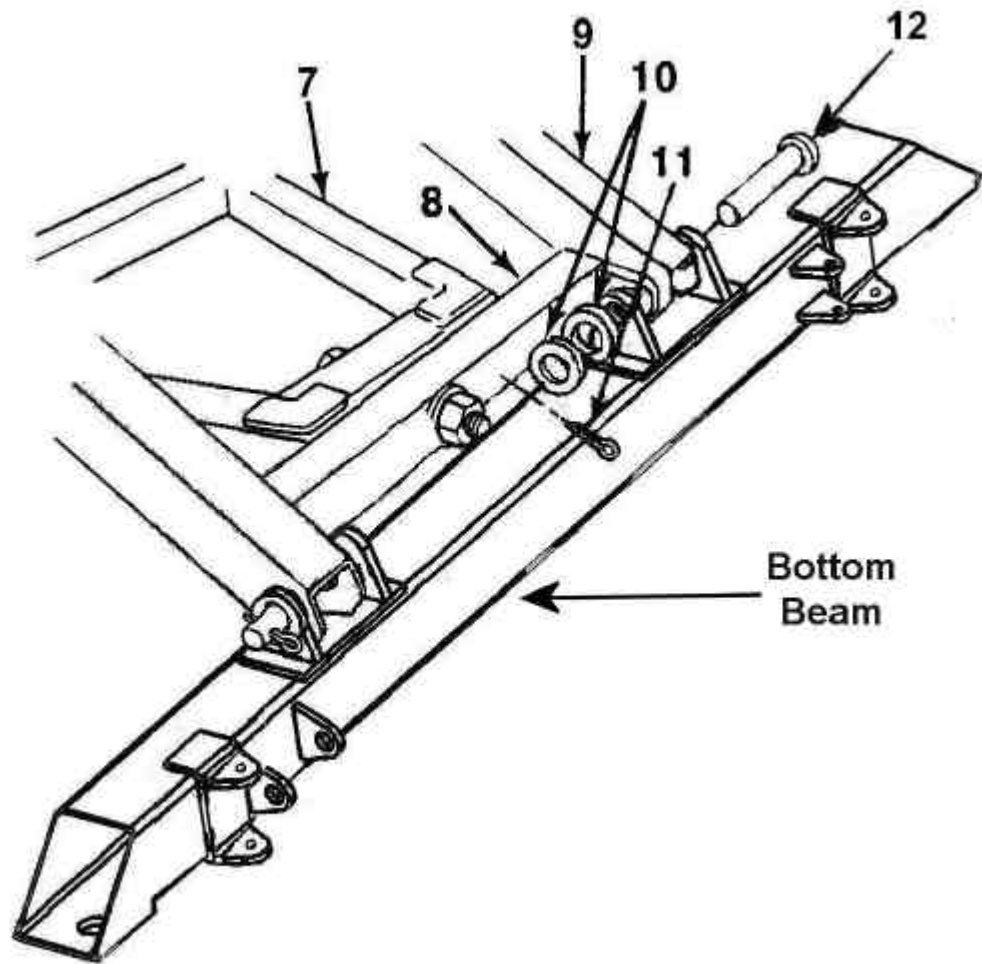

Figure 6

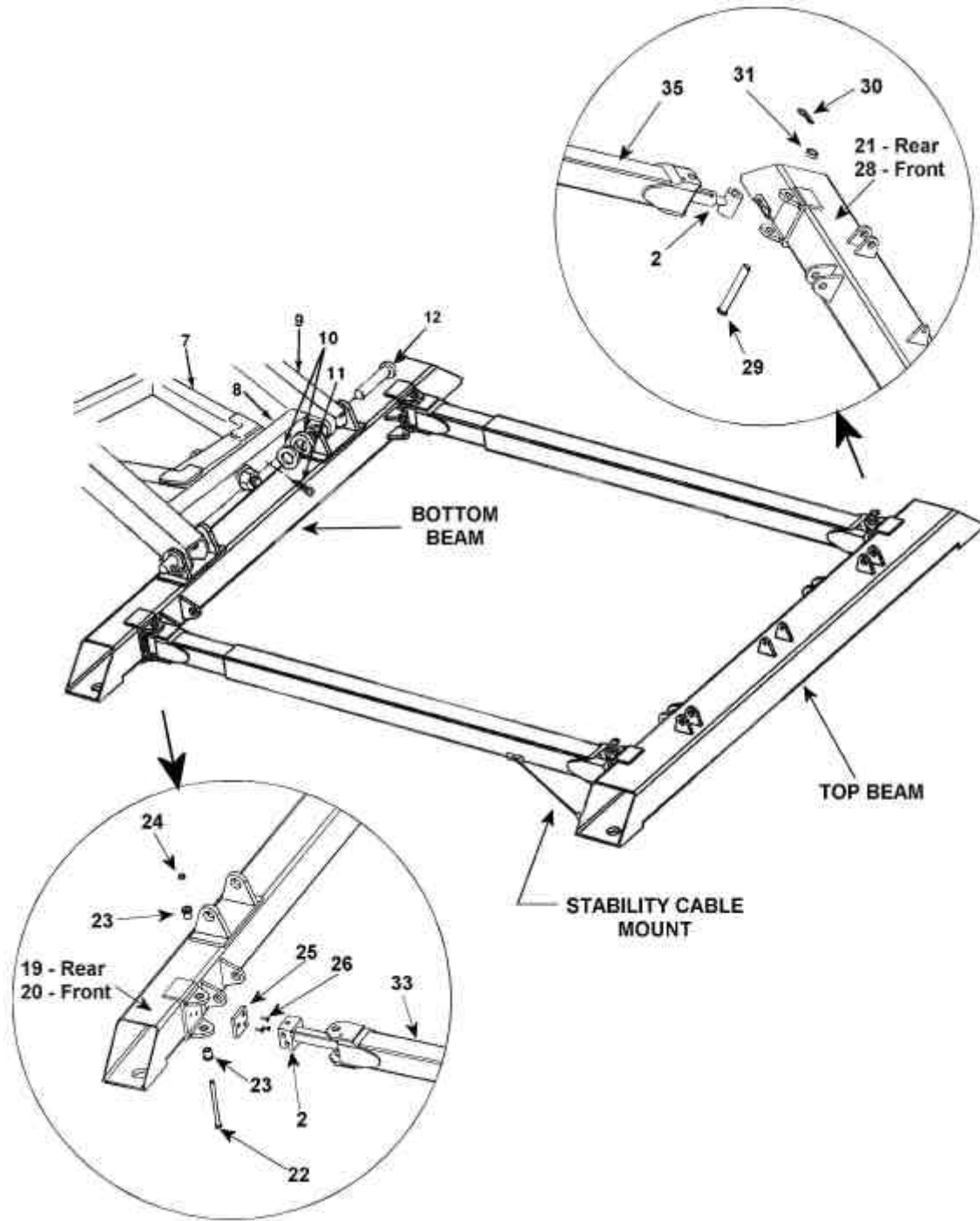

Figure 7

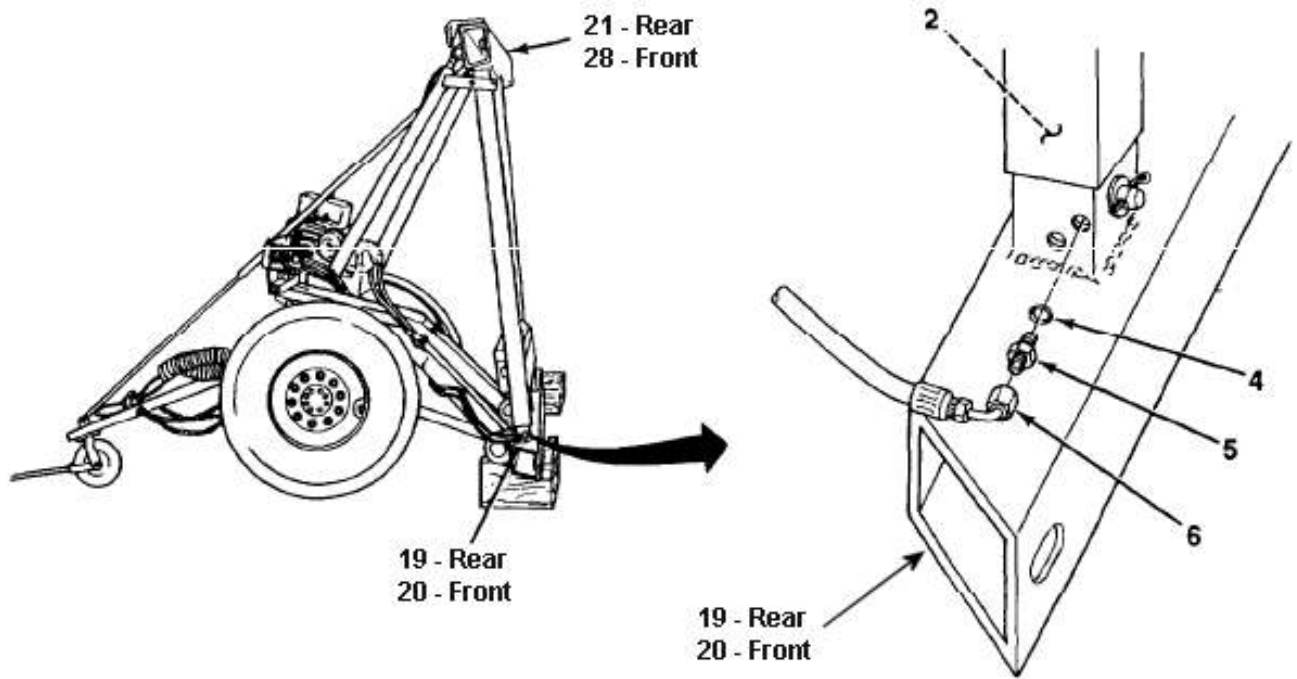

Figure 8

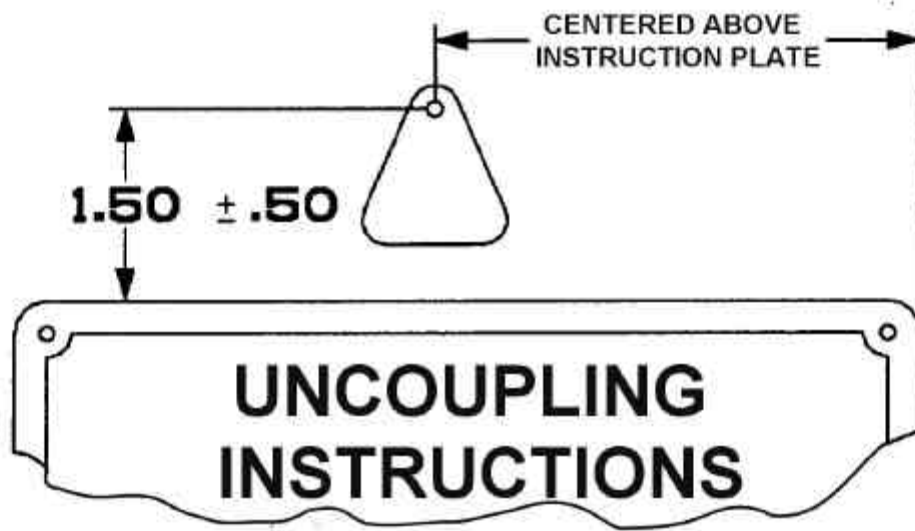

Figure 9

APPENDIX A: LOWERING DOLLY SET WITH OR WITHOUT SHELTER AND DETACHING FRONT AND REAR DOLLIES.

WARNING

- All personnel must use caution when standing near dolly set and shelter (if present) during lowering and detaching operations. Failure to follow this warning may cause serious injury or death to personnel.

NOTE

- Procedures to lower dolly set, with or without shelter, and detach front and rear dollies are similar. Differences will be identified as they occur.
- a. Remove stowage strap (36), lockpin (37), and pin (38), and remove rear drawbar (39) from stowage on bottom beam (3) of front dolly.

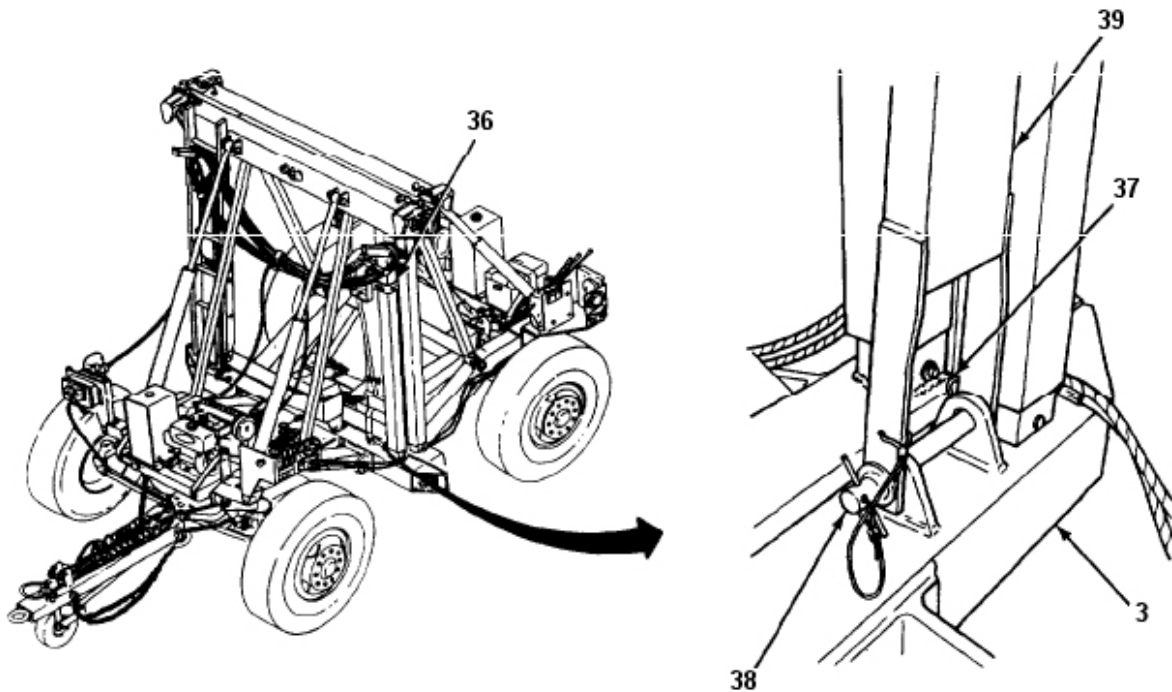

APPENDIX A: LOWERING DOLLY SET WITH OR WITHOUT SHELTER AND DETACHING FRONT AND REAR DOLLIES (Con't).

- b. Remove steering locking pin (40) from stowage tube (41). Install steering locking pin through front axle (42) and steering link (43) to lock steering.

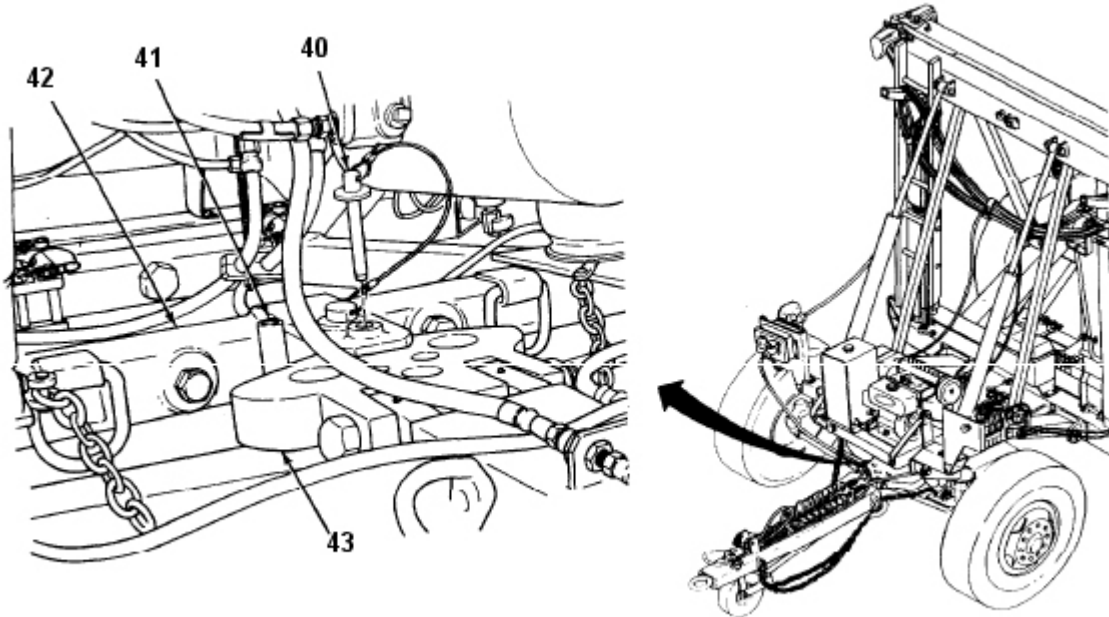

- c. At front and rear, remove two caps (44) of air bag valves (45) and deflate air bags (46). Install caps on air bag valves.

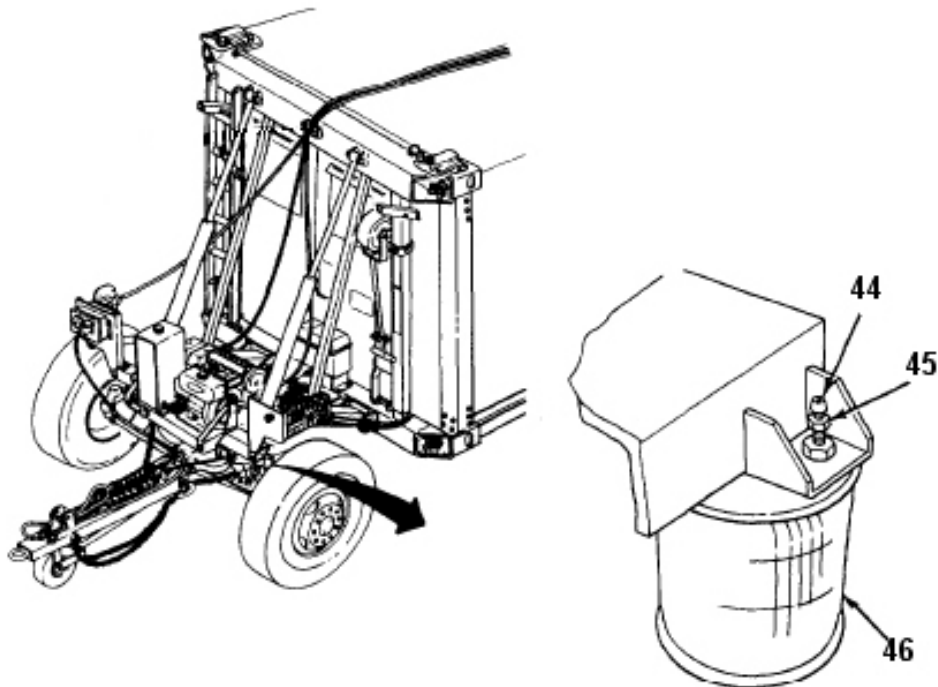

**APPENDIX A: LOWERING DOLLY SET WITH OR WITHOUT SHELTER
AND DETACHING FRONT AND REAR DOLLIES (Con't).**

- d. Install rear drawbar (39) to rear axle (47) with pin (38) and lockpin.
- e. Remove two stowage straps and ladder (88). Set ladder aside.

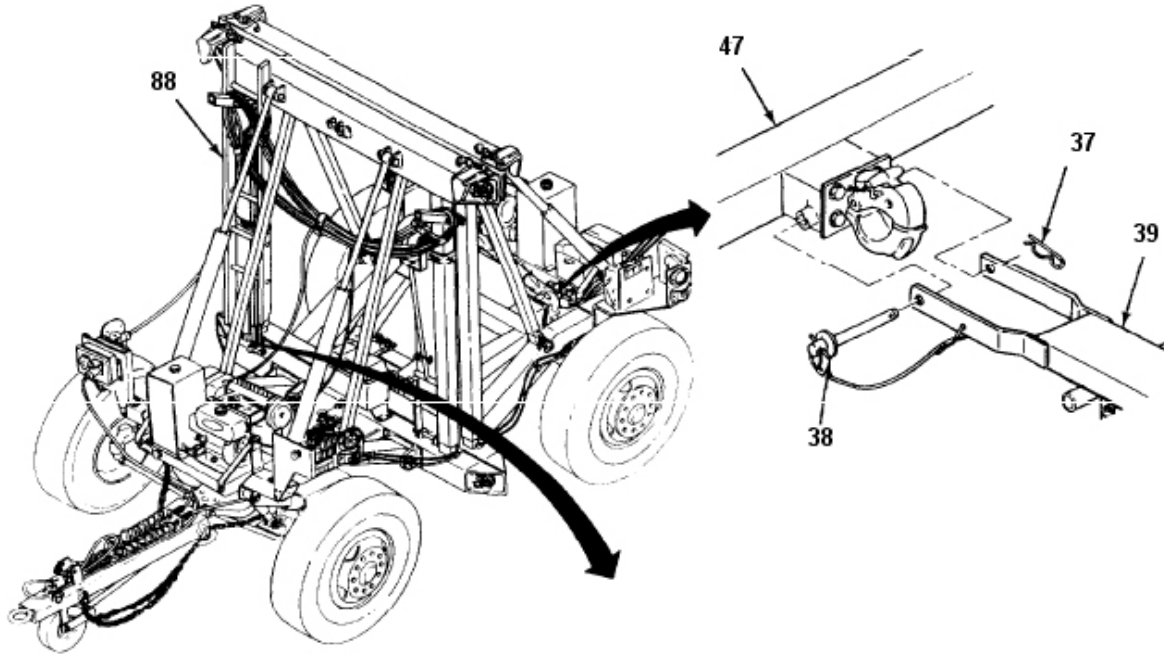

- f. Remove stowage strap and detent pin (48), and remove two telescopic braces (49) from stowage on bottom beam (3) of front dolly.

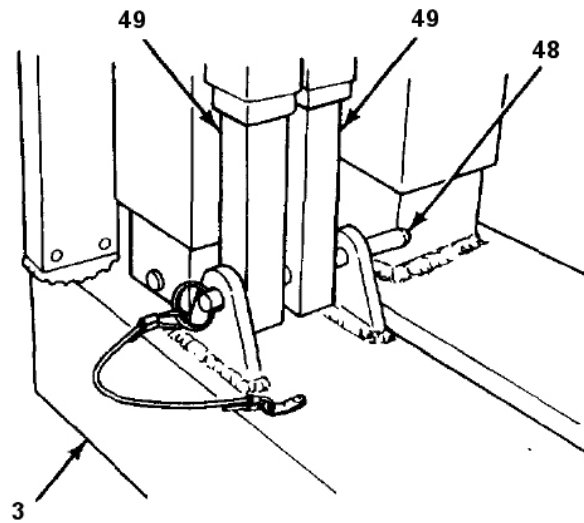

APPENDIX A: LOWERING DOLLY SET WITH OR WITHOUT SHELTER AND DETACHING FRONT AND REAR DOLLIES (Con't).

- g. Remove rest pin (50) from hole (51) at end of each larger brace (52). Install rest pin in fourth hole (53) from end of each smaller brace (54).

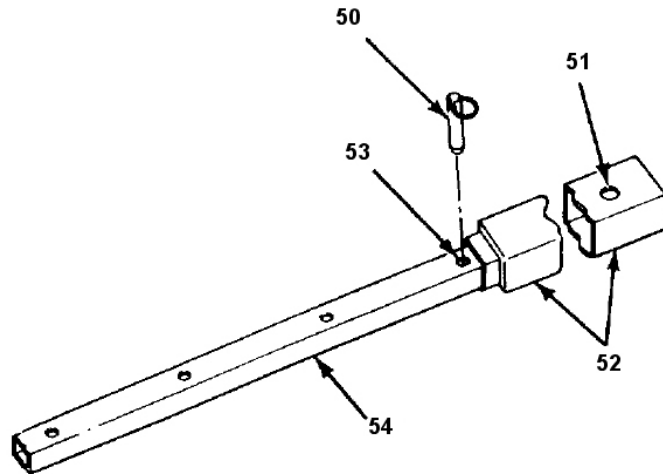

- h. Install two telescopic braces (49) to front and rear drawbars (55 and 39) and top beams (1) with four detent pins (89).

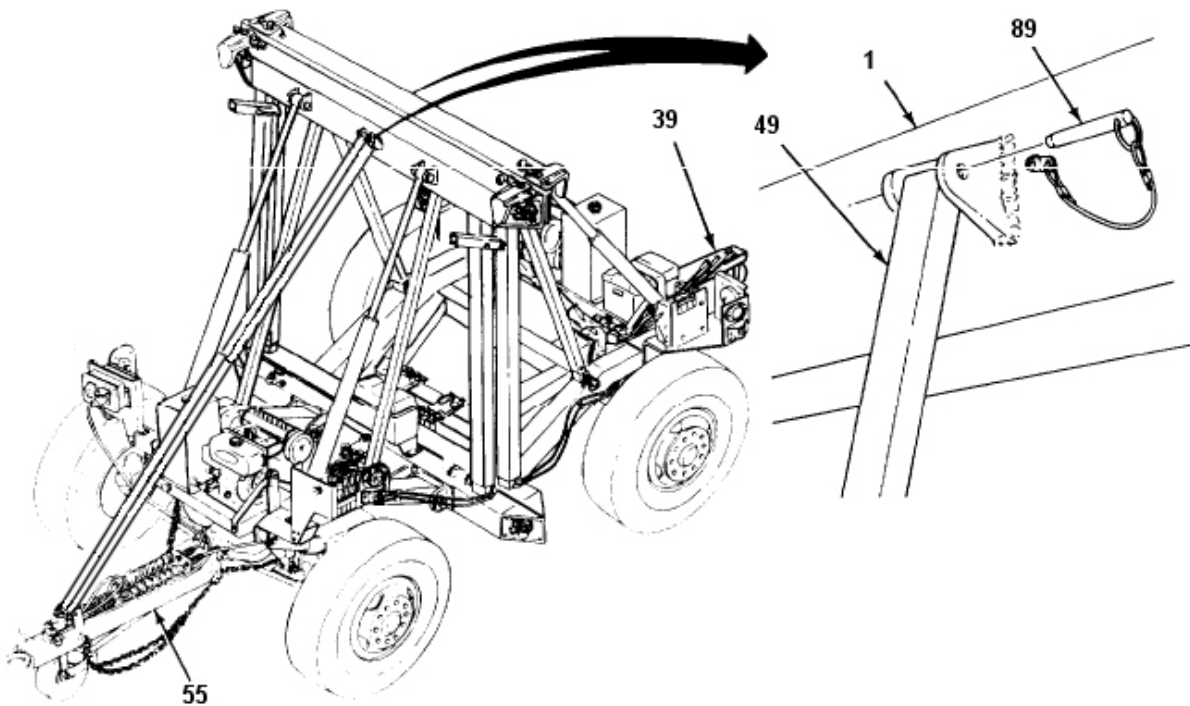

APPENDIX A: LOWERING DOLLY SET WITH OR WITHOUT SHELTER AND DETACHING FRONT AND REAR DOLLIES (Con't).

- i. Start engine at front and rear dollies.
- j. At front and rear, pull down on two-lift cylinder levers (56) to slightly extend lift cylinders. Disengage transportation lockouts (57) from suspension links (9). Secure each transportation lockout to top beam vertical tube (58) with stowage strap.

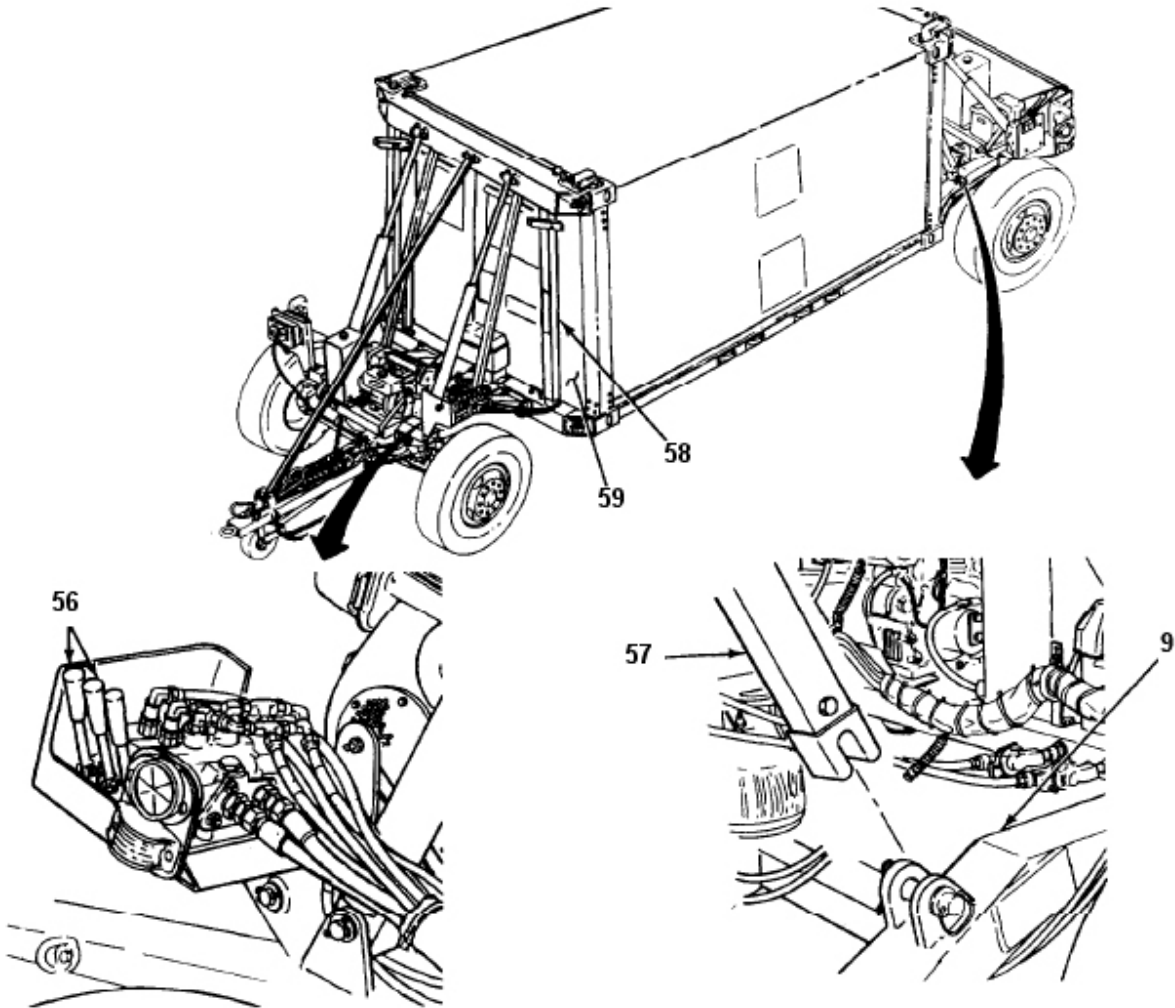

- k. At front and rear, push up on two lift cylinder levers (56) and lower dolly set with or without shelter (59) to the ground.

APPENDIX A: LOWERING DOLLY SET WITH OR WITHOUT SHELTER AND DETACHING FRONT AND REAR DOLLIES (Con't).

- l. Remove safety pin (60) and hitch pin (61) and release handle (62) from stowage under rear drawbar (39). Repeat for handle at front drawbar (55).

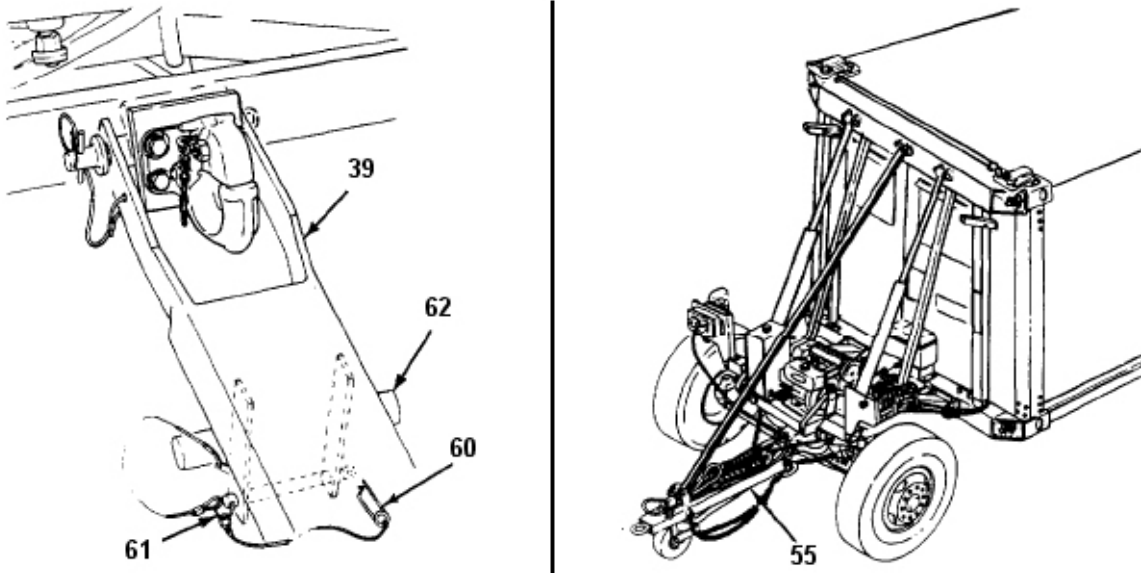

- m. Release brakes on rear dolly by pushing in on airbrake control knob (63) and turning parking brake lever (64) on pivoting tray (65) to OFF position.

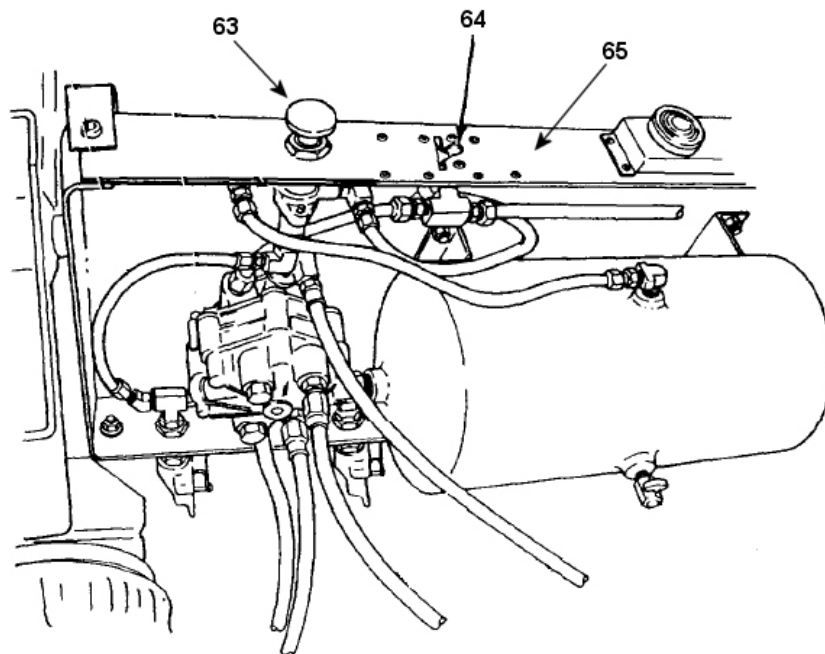

**APPENDIX A: LOWERING DOLLY SET WITH OR WITHOUT SHELTER
AND DETACHING FRONT AND REAR DOLLIES (Con't).**

WARNING

- Use extreme caution when removing twist locks. Keep hands and/or feet clear of top hooks, top and bottom beams, and from between beams and shelter. Failure to follow this warning may cause serious injury to personnel.
- Use extreme caution when loosening and removing twist locks. Loosened twist locks at top beam **MUST** be removed or they may fall, causing serious injury to personnel.
- Use extreme caution when using ladder. Have an assistant hold ladder to ensure that it is stable. Failure to follow this warning may cause serious injury to personnel.

NOTE

- If there is difficulty loosening twist lock nut or twist locks do not come out, it may be necessary to operate hydraulic control valve to slightly retract or extend each lift cylinder.
 - If detaching dolly halves from each other, perform step l. Skip remaining steps in task.
 - If detaching dolly halves from shelter, skip step n and perform steps o through s.
- n. At front and rear, remove safety pins (66). Use twist lock wrench (table 9a) to loosen nuts (67) at top beams (1). Rotate twist locks (68) 90° and remove from top beams. Repeat to remove from bottom beams (3). Stow twist locks in toolbox (69) on front dolly.

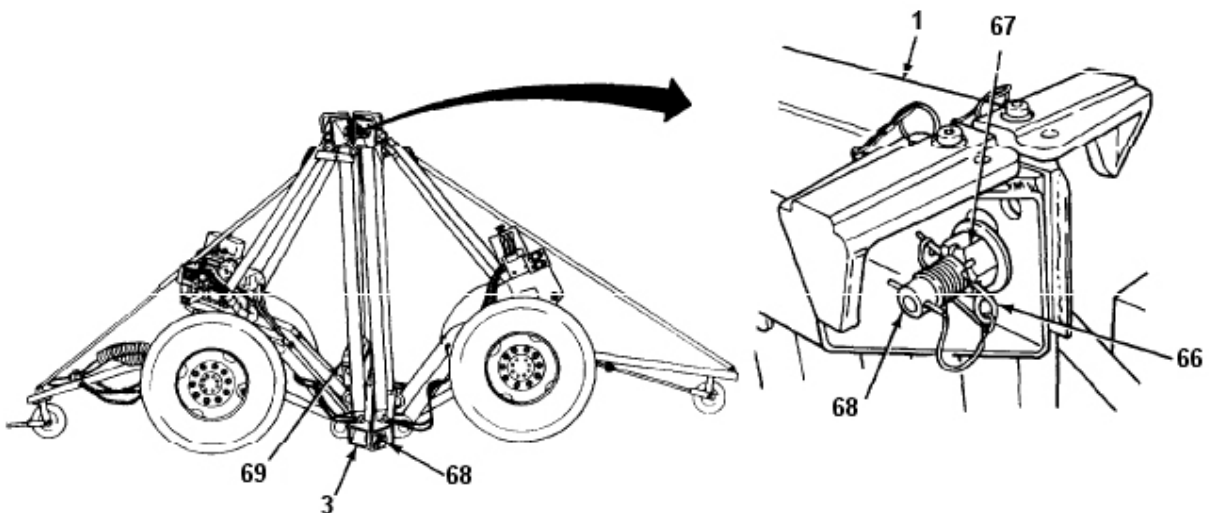

APPENDIX A: LOWERING DOLLY SET WITH OR WITHOUT SHELTER AND DETACHING FRONT AND REAR DOLLIES (Con't).

- o. At front and rear, remove safety pins (66). Use twist lock wrench (table 9a) to loosen nuts (67) at top and bottom beams (1 and 3). Rotate twist locks (68) 90° and remove from top beams and shelter (59). Stow removed twist locks in toolbox (69) on front dolly.
- p. At bottom beams (3) rotate twist locks (68) 90°. Pull out, but DO NOT remove twist locks. Ensure that heads of twist locks are aligned with holes in corner blocks (70) of shelter (59).
- q. At front and rear, pull down on two lift cylinder levers (56) to extend lift cylinders. Stop when bottom beam (3) is approximately 6 in. (15 cm) from shelter (59) and twist locks (68) are free of corner blocks (70).

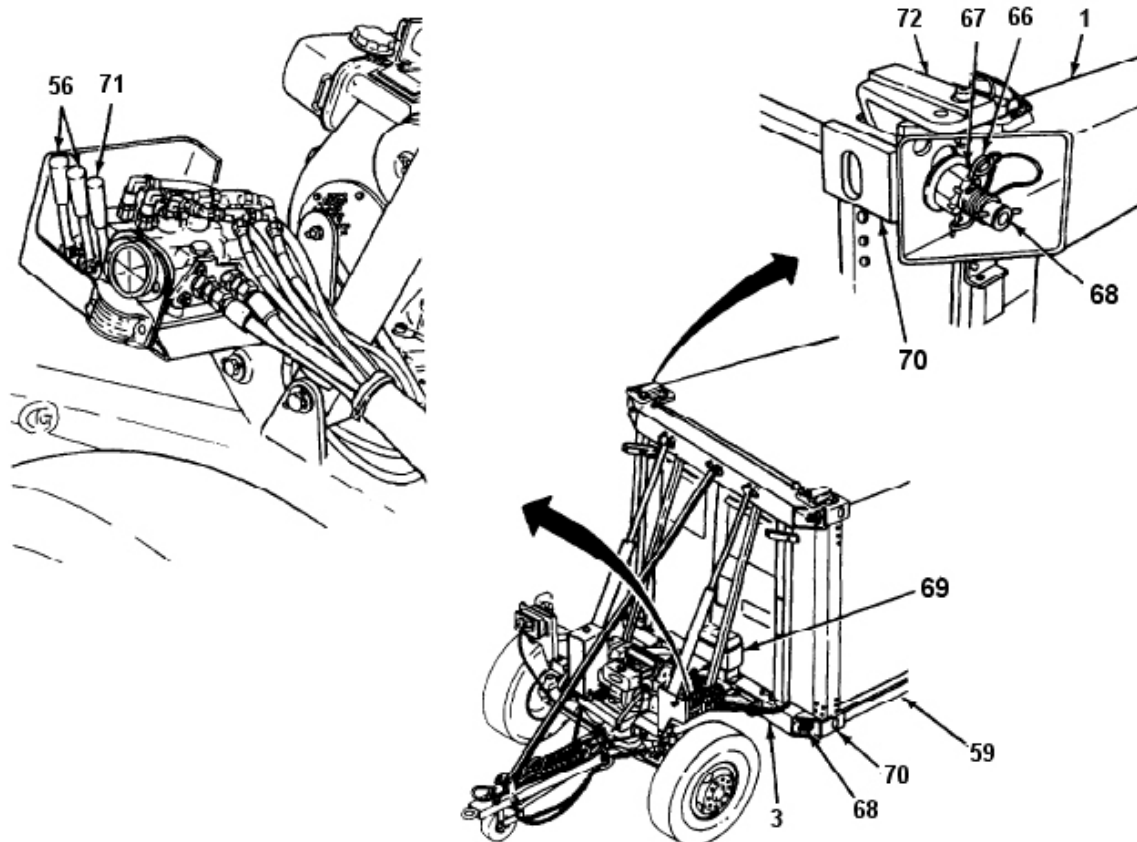

- r. At front and rear, pull down on positioning cylinders lever (71) until bottom beam (3) rests on the ground.
- s. At front and rear, briefly pull down on two lift cylinder levers (56) and then briefly pull down on positioning cylinders lever (71). Repeat as required until top hooks (34) are clear of corner blocks (70) at top of shelter (59).

APPENDIX B. MANEUVERING POSITION

a. Placing Dolly Half in Maneuvering Position.

WARNING

- **DO NOT** operate control valve levers to put front or rear dolly in maneuvering position unless telescopic brace and front axle steering locking pin are installed. Telescopic brace and front axle steering locking pin must **ALWAYS** be installed before lift cylinders reach their vertical position. Failure to follow this warning may cause front or rear dolly to overturn, resulting in serious injury or death to personnel.

CAUTION

- Use extreme caution to ensure that near (left side) top beam vertical tube does not contact control valve and fittings and cause damage when placing dolly half in maneuvering position. Carefully follow all steps and monitor position of lift cylinders and pivoting tray to guard against binding and interference.

NOTE

- The maneuvering position is a three-wheel configuration. The dolly half's center of gravity is shifted over the axle, the top beam is resting over the drawbar, and the axle is level with the ground. In this position, the dolly half can be easily moved and positioned where required.
- Before proceeding, ensure that all stowed items such as rear drawbar, ladder, and intradolly air hoses and cable have been removed; air bags must be deflated; transportation lockouts have been secured to top beam vertical tubes with stowage straps; and toolbox has been closed.
- The following steps are performed at the front and/or rear dolly as required. Procedure begins with bottom beam resting on ground with top and bottom beams vertical and engines running at high idle.
 - (1) Ensure that front axle steering locking pin (40) is installed to lock steering. Ensure that telescopic braces are installed.
 - (2) Pull down on positioning cylinders lever (71) to extend positioning cylinders (2) until telescopic brace (49) reaches rest pin (50).
 - (3) Quickly push up on positioning cylinders lever (71) to FLOAT position.

APPENDIX B. MANEUVERING POSITION (Con't).

CAUTION

- Proceed slowly and with caution to prevent equipment damage.

NOTE

- If operating a dolly half equipped with side lift kit, extension of lift and positioning cylinders should stop when top beam vertical tubes have extended approximately 49 in. (124 cm) and positioning cylinder limit lines are just visible.
- (4) Pull down on two lift cylinder levers (56) to extend lift cylinders (73) and positioning cylinders (2). Stop when near (left side) top beam vertical tube (58) reaches within ½ in. (13 mm) of hydraulic control valve (74) and fittings (90).
- (5) Continue to pull down on two lift cylinder levers (56), allowing near (left side) lift cylinder (73) to lead far (right side) lift cylinder. Maintain clearance of 1/8 in. (13 mm).

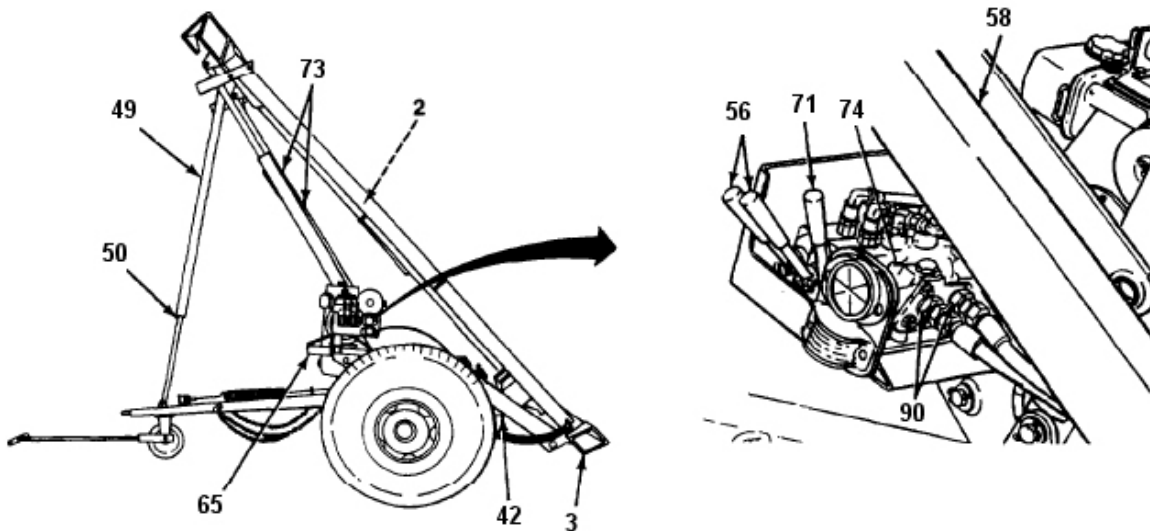

- (6) If operating a dolly half equipped with side lift kit, return positioning cylinders lever (71) to NEUTRAL position.
- (7) Continue to pull down on two lift cylinder levers (56) until bottom beam (3) is raised off the ground and axle (42) and pivoting tray (65) are parallel to the ground. Dolly half is now in maneuvering position.

WARNING

- While in maneuvering position, DO NOT operate positioning cylinders lever. Failure to follow this warning may cause bottom beam to lower to the ground, causing serious injury to personnel.
- (8) Return positioning cylinders lever (71) to NEUTRAL position, as required.

APPENDIX B. MANEUVERING POSITION (Con't).

b. Removing Dolly Half From Maneuvering Position.

CAUTION

- Use extreme caution to ensure that near (left side) top beam vertical tube does not contact control valve and fittings and cause damage when removing dolly half from maneuvering position. Carefully follow all steps and monitor position of lift cylinders and pivoting tray to guard against blinding and interference.

NOTE

- The following steps are performed at the front and/or rear dolly as required. When procedure has been completed, bottom beam will be resting on ground with top and bottom beams vertical.
- (1) Push up on two lift cylinder levers (56) to retract lift cylinders (73). Stop when near (left side) top beam vertical tube (58) reaches within ½ in. (13 mm) of hydraulic control valve (74) and fittings (90).
 - (2) Continue to push up on two lift cylinder levers (56), allowing far (right side) lift cylinder (73) to lead near (left side) lift cylinder. Maintain clearance of ½ in. (13 mm).
 - (3) Continue to push up on two lift cylinder levers (56) until bottom beam (3) rests on ground.
 - (4) Quickly push up on positioning cylinders lever (71) to FLOAT position.
 - (5) Push up on lift cylinder levers (56) to retract lift cylinders (73) until approximately 6 in. (15 cm) of stroke remain on lift cylinders.
 - (6) Return positioning cylinders lever (71) to NEUTRAL position.
 - (7) Push up on positioning cylinders lever (71) until top and bottom beams (1 and 3) are vertical.

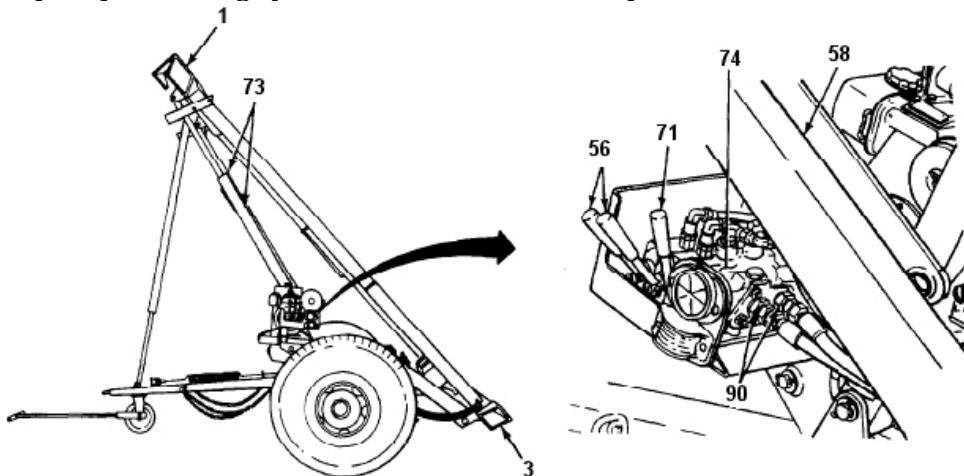

**APPENDIX C: TOP AND BOTTOM BEAM AND HYDRAULIC LIFT
CYLINDER REMOVAL / INSTALLATION**

a. REMOVAL

WARNING

- Use extreme caution when handling heavy parts. Lifting device is required when parts weight over 50 lb (23 kg) for a single person lift, over 100 lb (45 kg) for a two person lift, and over 150 lb (63 kg) for a three or more person lift. Keep clear of heavy parts supported only by lifting device. Failure to follow this warning may cause serious injury or death to personnel.
- DO NOT attempt to replace both lift cylinders at the same time unless dolly halves are attached to each other or top beam is supported by a suitable lifting device. If top beam is not supported, it will fall to the ground. Failure to follow this warning will cause serious injury or death to personnel.

NOTE

- Procedures are the same for front and rear dollies. Rear dolly is illustrated.
1. Attach a suitable lifting device to top beam (1) and adjust so that weight of top beam is on the lifting device.
 2. Remove telescopic brace.

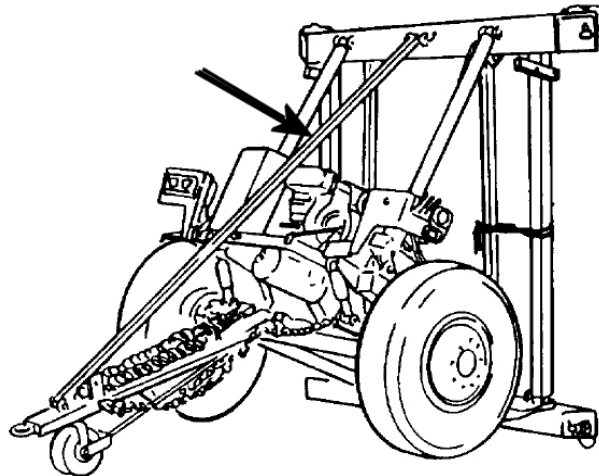

4. Support lift cylinder (73) with a suitable lifting device.
5. Remove cotter pin (75), flat washer (76), and clevis pin (77) from hydraulic lift cylinder (73) and top beam (1). Discard cotter pin.

APPENDIX C: TOP AND BOTTOM BEAM AND HYDRAULIC LIFT CYLINDER REMOVAL / INSTALLATION (Con't).

NOTE

- **DO NOT** disconnect hydraulic lift cylinder lower connections from suspension link.

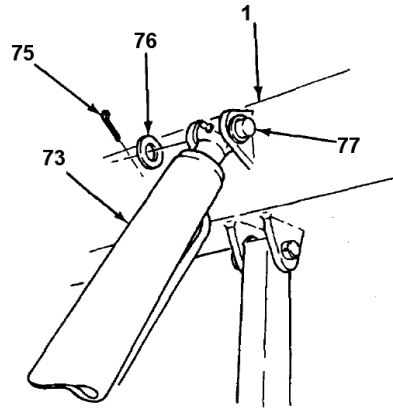

6. Swing cylinder back and support utilizing rubber vehicle chocks, NSN 2540-01-052-6234, P/N MS 52127-2 or equivalent, between cylinder and dolly suspension structure.
7. Remove cotter pins (15 & 16), flat washers (14 & 17), and clevis pins (13 & 18) from positioning cylinders (2), top and bottom beam. Discard cotter pins, washers, and clevis pins.
8. Optional: Lockout brackets (81) may interfere with bottom support beam when lowered. If needed, lockout brackets may be removed. To do so, remove eight safety pins (78) from bolts (79). Remove four nuts (80), bolts (79), bottom lockout bracket (81), four sleeves (82), and top lockout bracket (83) from each end of pivot axle bracket (8) and axle assembly (7).

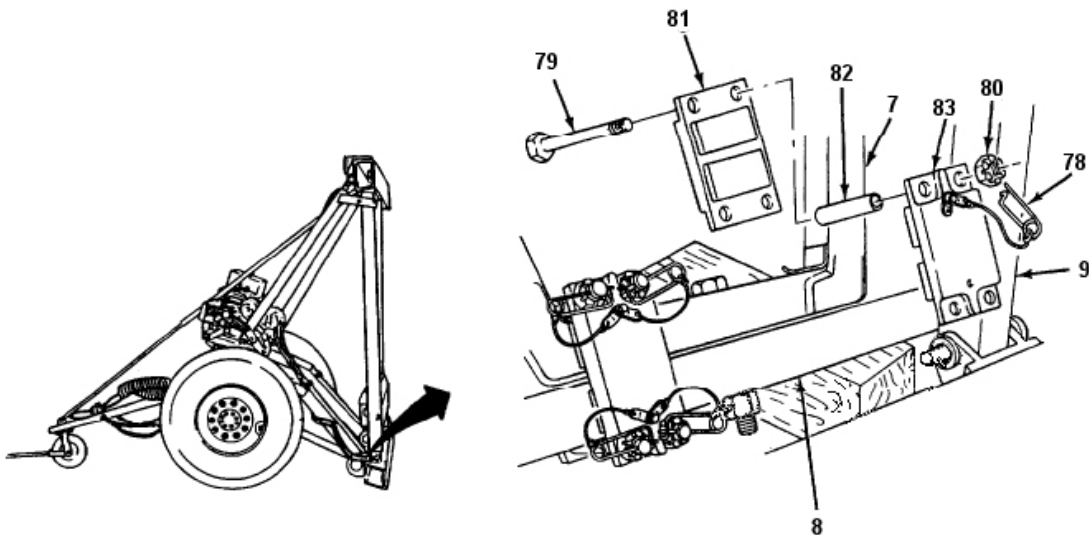

APPENDIX C: TOP AND BOTTOM BEAM AND HYDRAULIC LIFT CYLINDER REMOVAL / INSTALLATION (Con't).

WARNING

- Use extreme caution when lowering top and bottom beams and placing on the ground. Ensure that lifting device is secure and all personnel stand clear. Failure to follow this warning may cause serious injury to personnel or damage to beams and positioning cylinders.
9. Lower top and bottom beams to the ground and support on wooden blocks or other cribbing if necessary.

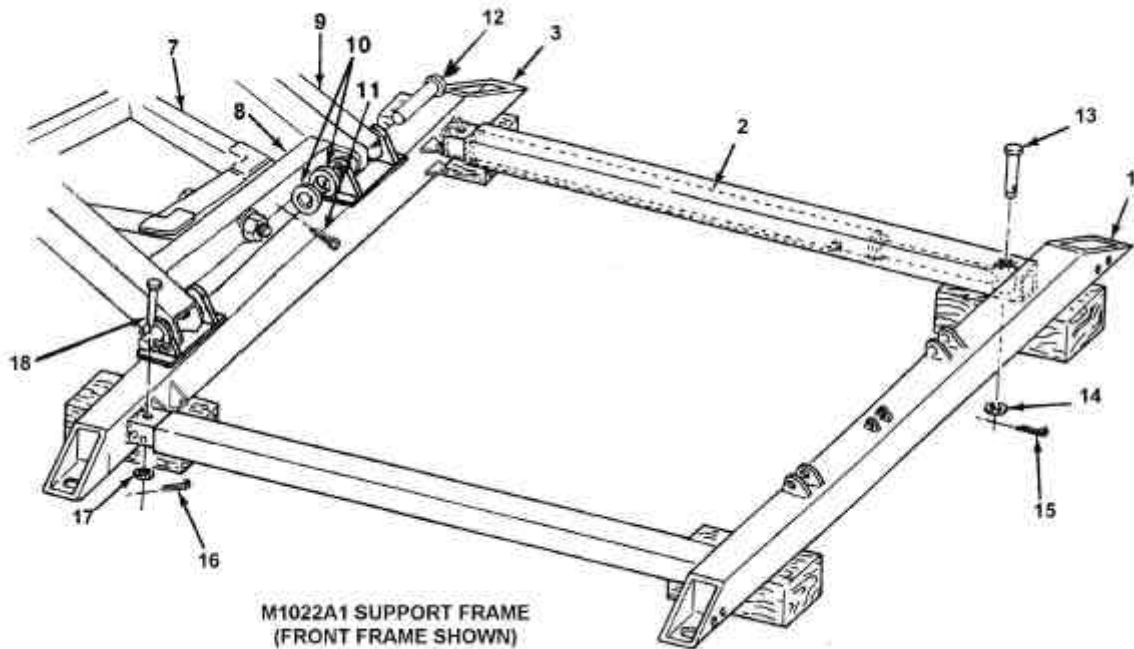

10. Swing lift cylinders forward to rest on suspension frame. This will counteract the removal of the top and bottom beam.

WARNING

- **DO NOT** disconnect hydraulic lines and fittings while engine is running or before hydraulic system pressure has been released. When engine is running, hydraulic system is under pressure. Dolly set must be fully lowered on to the blocks and the engine must be shut down before lines and fittings are disconnected. A line or fitting disconnected under pressure will explode with great force and cause serious injury or death to personnel.

APPENDIX C: TOP AND BOTTOM BEAM AND HYDRAULIC LIFT CYLINDER REMOVAL / INSTALLATION (Con't).

- Escaping hydraulic fluid under pressure can penetrate the skin, causing serious injury to personnel. Relieve pressure before disconnecting hydraulic lines and fittings. Tighten all connections before applying pressure. Keep hands and body away from pinholes and nozzles that eject hydraulic fluid under high pressure. Use a piece of cardboard or paper to search for leaks. If any hydraulic fluid is injected into the skin, it **MUST** be surgically removed within a few hours by a doctor familiar with this type of injury or gangrene may result.
11. Disconnect two hose assemblies (6) from straight connectors (5) at positioning cylinders (2) inside bottom beam (3).
 12. Remove two straight connectors (5) and preformed packings (4) from positioning cylinders (2). Discard preformed packings.

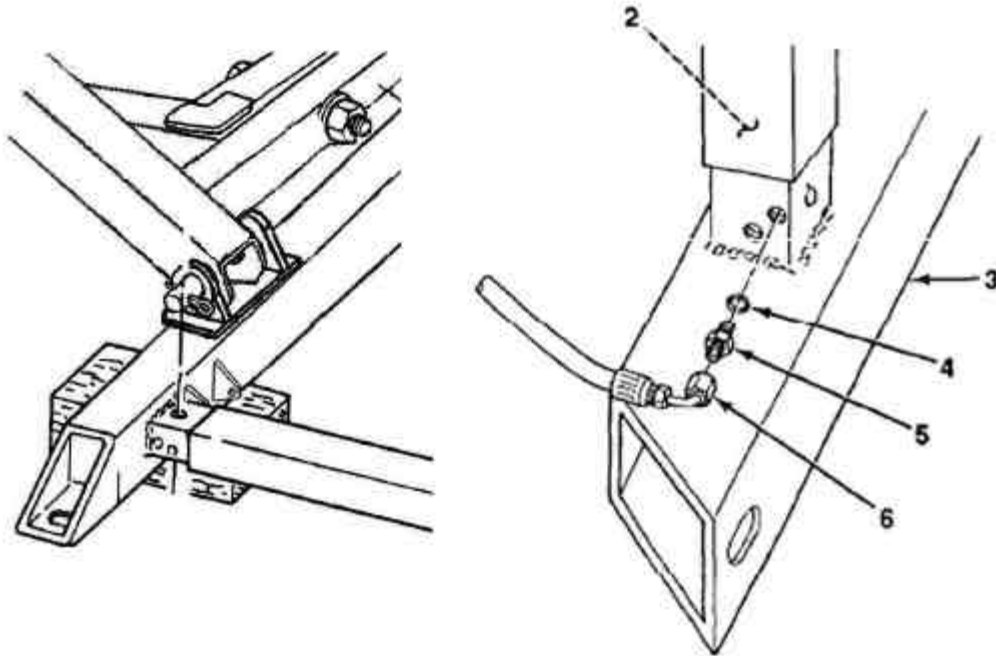

13. With top beam (1) suitably supported, remove top beam with upper vertical positioning tubes from positioning cylinders (2) and bottom beam (3).
14. Remove two positioning cylinders (2) from bottom beam (3). Place positioning cylinders on a clean work surface.
15. Remove cotter pin (11), washers (10) and clevis pin (12) and detach bottom beam from suspension structure. Discard cotter pins only. Save washers and clevis pins for later use.
16. Place both top and bottom beams with associated positioning tubes aside as scrap.

APPENDIX C: TOP AND BOTTOM BEAM AND HYDRAULIC LIFT CYLINDER REMOVAL / INSTALLATION (Con't).

b. INSTALLATION

1. Position bottom beam to align suspension mount tabs with suspension frame (9).
2. Using tapered chase pins supplied with kit, attach bottom beam to suspension frame (9). Insure that washers (10) previously removed are reinstalled to consume gaps that may exist.
3. Drive each tapered chase pin out of connection made in task 2 with clevis pin (12). Use proper care to avoid inference with suspension member (9) and washers (10).
4. After each clevis pin (12) is installed, insert new cotter pin (9) to complete connection.

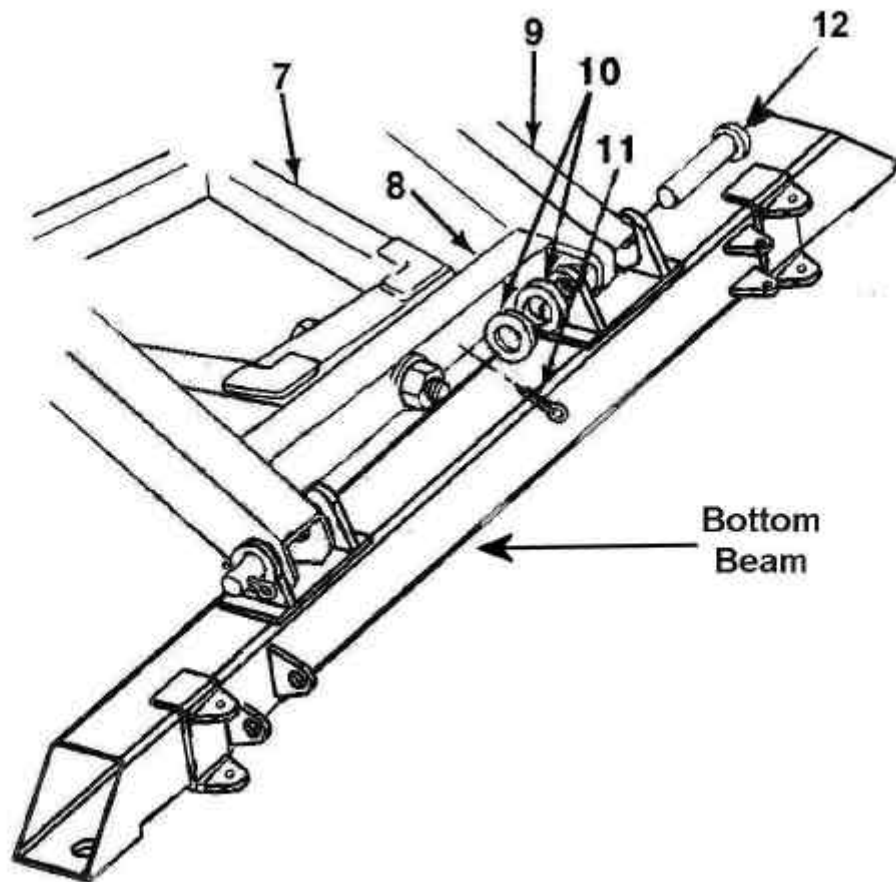

5. Attach cylinder shims (25) to tube mounts on bottom beam (19 – Rear, 20-Front) using flat head screws (26). Torque each screw to 10 ft-lbs.
6. Position mounting tabs on lower vertical tube (33) between the tube mount tabs on the bottom beam.

APPENDIX C: TOP AND BOTTOM BEAM AND HYDRAULIC LIFT CYLINDER REMOVAL / INSTALLATION (Con't).

NOTE

- Ensure that openings for hydraulic fittings in positioning cylinders are aligned with holes in bottom.
- To ensure proper assembly, install items (22), (23), (24) as illustrated below.

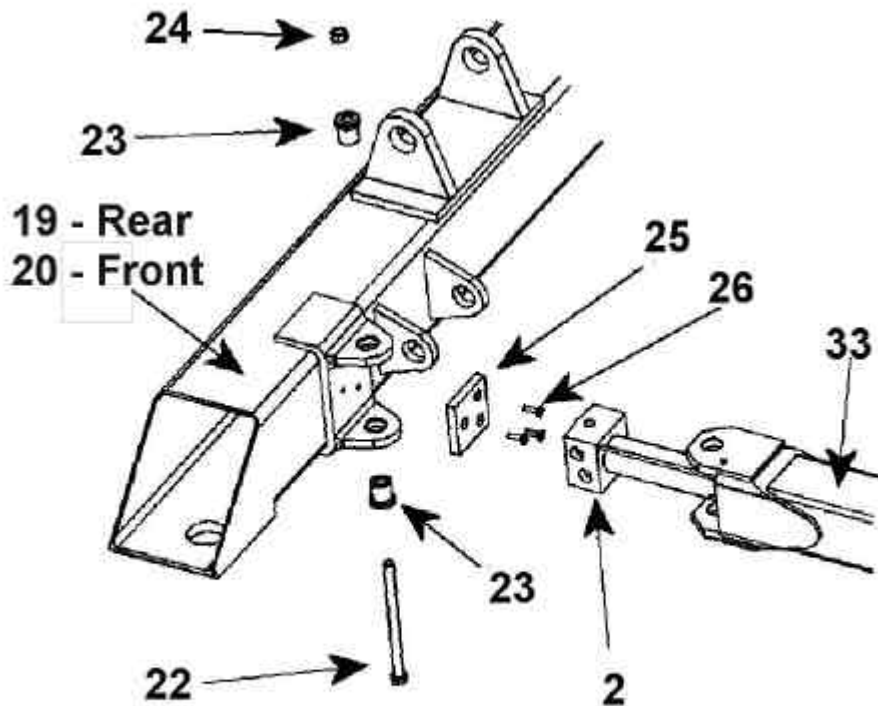

**LOWER POSITIONING
TUBE CONNECTION**

7. Insert the positioning cylinder (2) into the lower vertical tube (33) with the hydraulic connections facing outboard.
8. Insert bolt (22) through one steel bushing (23) with bushing shoulder adjacent to bolt head. The bolt and bushing sub-assembly should insert through the tube mounting tabs on the bottom beam, the lower vertical tube (34) and the positioning cylinder base (2).
9. After insertion, place a second steel bushing (23) onto bolt (22). Finish the lower tube connection by placing locking nut (24) onto bolt (22). Prior to the application of torque, insure that each of the steel bushings (23) fit into the holes in each tab of the tube mount.
10. Torque lower tube connection bolts (22) to 25-30 ft-lbs.
11. Repeat steps 5 through 10 to complete second lower tube connection.

APPENDIX C: TOP AND BOTTOM BEAM AND HYDRAULIC LIFT CYLINDER REMOVAL / INSTALLATION (Con't).

12. Slide one of the upper vertical tubes (34 or 35) over an assembled lower vertical tube. Proper assembly will have the stability cable mount positioned outboard and to the container mounting surface.

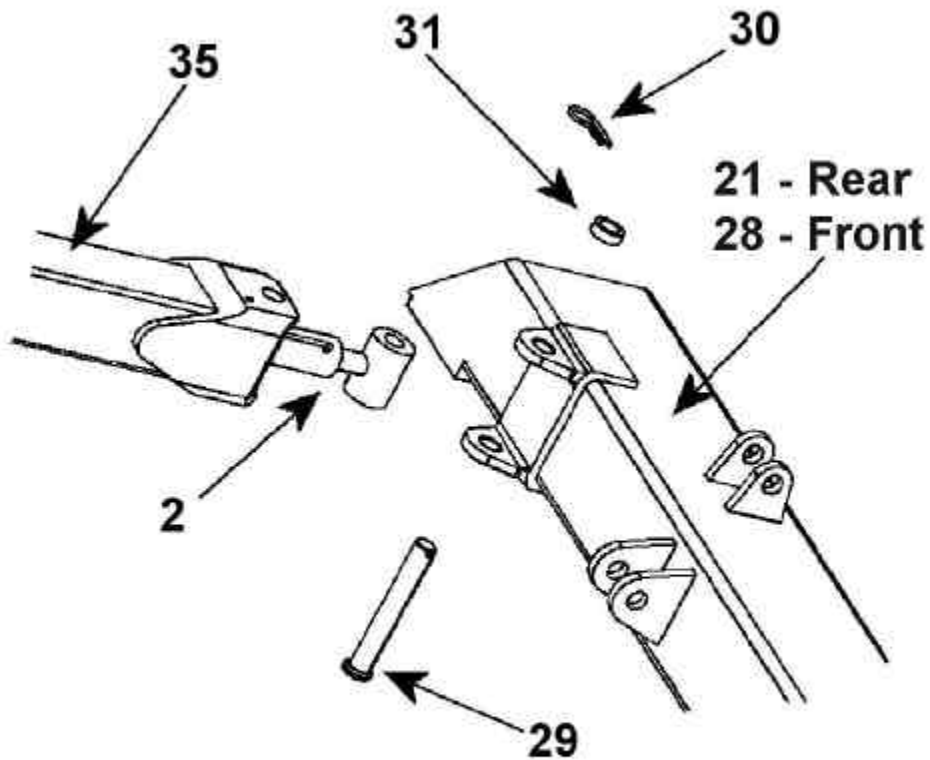

**UPPER POSITIONING
TUBE CONNECTION**

NOTE

- Ensure that the hole at rod end of positioning cylinder is aligned with hole in top beam.
- To ensure proper assembly install items (29), (30), (31) as illustrated above.

13. Insert clevis pin (29) into upper vertical tube (34 or 35), tube mounting tabs on the upper beam (21 – Rear, 28 - Front), and the positioning cylinder rod end (2).
14. Add spacer (31) to free end of clevis pin (29).
15. Insert cotter pin (30) to complete upper tube connection.
16. Repeat steps 12 though 15 to complete second upper tube connection.

APPENDIX C: TOP AND BOTTOM BEAM AND HYDRAULIC LIFT CYLINDER REMOVAL / INSTALLATION (Con't).

WARNING

- Use extreme caution when raising top and bottom beams. Ensure that lifting device is secure and all personnel stand clear. Failure to follow warning may cause serious injury to personnel or damage to beams and positioning cylinders.

17. Raise the assembled top and bottom beams with positioning cylinders (2) installed to a vertical position.

18. If lockout brackets were removed, reinstall at this time. To do so, coat four bolts (79) with grease. Install top lockout bracket (81), four sleeves (82), bottom lockout bracket (81), four bolts and nuts (80) on each end of pivot axle assembly (8) and axle assembly (7). Hand tighten nuts, then tighten with wrench 1 ¼ to 2 flats. Install eight safety pins (78) on bolts (79).

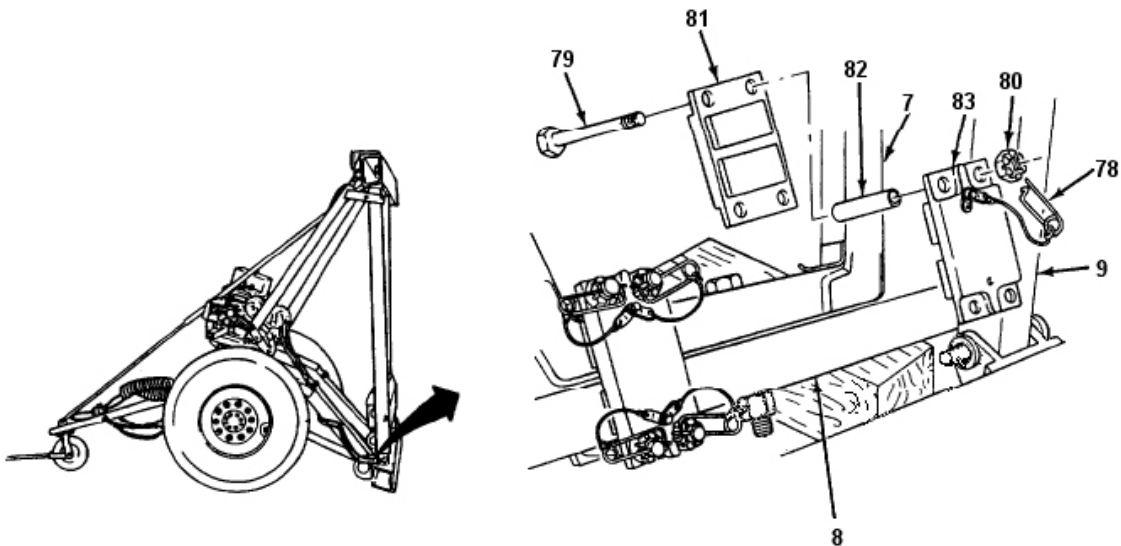

19. Support hydraulic lift cylinder (73) with a suitable lifting device.

20. Install hydraulic lift cylinder (73) on top beam (21 – Front, 28 - Rear) with clevis pin (77), flat washer (76), and new cotter pin (75).

21. Remove lifting device from hydraulic cylinder (73).

22. Install telescopic brace.

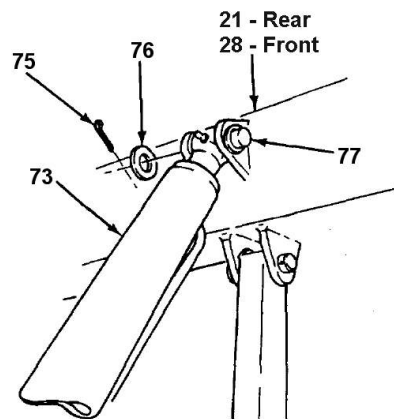

APPENDIX C: TOP AND BOTTOM BEAM AND HYDRAULIC LIFT CYLINDER REMOVAL / INSTALLATION (Con't).

NOTE

- Preformed packings should be lightly coated with hydraulic fluid before installation.
23. Install two new preformed packings (4) and straight connectors (5) on positioning cylinders (2) inside bottom beam (19 – Rear, 20 Front).
24. Connect two hose assemblies (6) to straight connectors (5) at positioning cylinders (2).

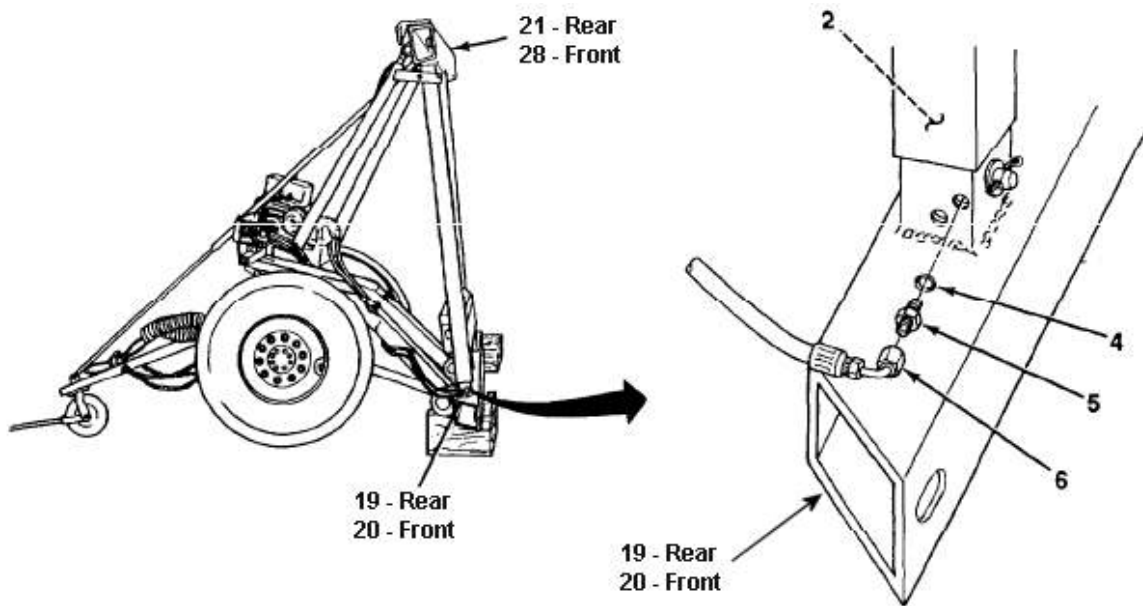

Follow-on Tasks:

- Install toolbox (front dolly).
- Bleed hydraulic system if necessary. (See Appendix D).
- Check for leaks.
- Remove wooden blocks from ends of bottom beam.
- Ensure proper air inflation in air bags.

APPENDIX D: HYDRAULIC SYSTEM BLEEDING

This Task Covers: Bleeding

Initial Setup:

Equipment Conditions:

- Front and rear dollies lowered and detached

Tools/Test Equipment:

- Suitable lifting device, 5000 lb capacity minimum.

Materials/Parts:

- Hydraulic fluid (MIL-H-5606)
 - Rags
-

WARNING

- Top beams of front and rear dollies must be secured with a suitable lifting device throughout entire bleeding procedure if bleeding hydraulic system of a dolly set with side lift kit when **ONLY** side lift positioning cylinders were replaced. Top and bottom beams must also be kept vertical. Until bleeding is complete, air in the hydraulic system may cause erratic movement when extending and retracting hydraulic cylinders. Failure to support top beams and to keep tops and bottoms beams vertical may cause an accident resulting in serious injury or death to personnel.

CAUTION

- **DO NOT** allow dirt or dust to enter hydraulic reservoir. Damage to hydraulic system will result.

NOTE

- This procedure is used to bleed the hydraulic system of a dolly half without side lift kit **OR** a dolly set with side lift kit when only side lift positioning cylinders were replaced.

BLEEDING

1. Remove safety pin (84) and hitch pin (85) and unlock pivoting tray lockout brace (86) from lower bracket (87).

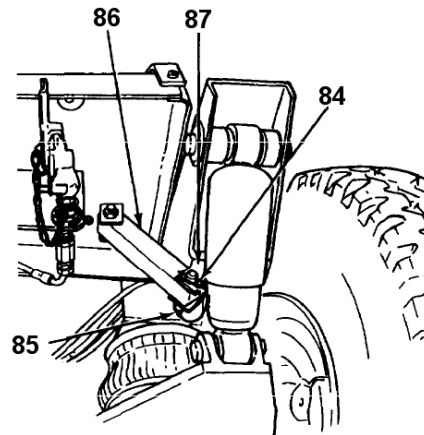

APPENDIX D: HYDRAULIC SYSTEM BLEEDING (Con't).

NOTE

- If bleeding hydraulic system of a dolly set with side lift kit, when **ONLY** side lift positioning cylinders were replaced, top beams must be supported by a suitable lifting device capable of raising 16 ft (4.9 m) above the floor. A sling with minimum capacity of 5000 lb (2270 kg) must be used.

2. Support top beam (1) with a lifting device as required.
3. Start engine.
4. Fill hydraulic reservoir.

NOTE

- **During extension, maintain slack in hoist sling as top beam is raised.**
5. Operate hydraulic control valve to extend lift cylinders (73) and positioning cylinders (2) in turn. Keep top and bottom beams (1 and 3) vertical as cylinders are extended.
 6. When full extension is reached, hold lift cylinder levers (56) and positioning cylinders lever (71) in extend position for 30 seconds.

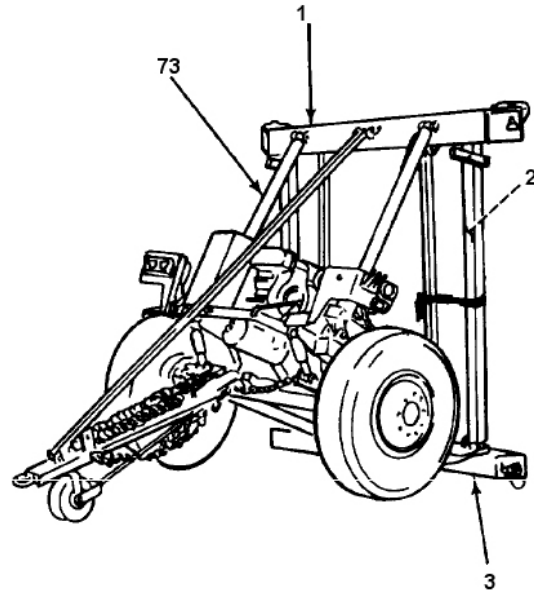

NOTE

- **During retraction, maintain slack in hoist sling as top beam is lowered.**
7. Operate hydraulic control valve to retract lift cylinders (73) and positioning cylinders (2) in turn. Keep top and bottom beams (1 and 3) vertical as cylinders are retracted.
 8. When full retraction is reached, hold lift cylinder levers (56) and positioning cylinders lever (71) in retract position for 30 seconds.

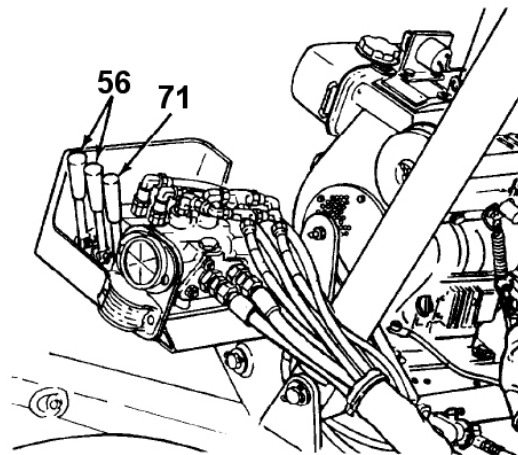

APPENDIX D: HYDRAULIC SYSTEM BLEEDING (Con't).

9. Shut down engine.
10. Check hydraulic fluid level and fill as required.
11. Repeat steps 5 through 8 two more times or until operation of hydraulic system is smooth.
12. Remove support from top beam (1) as required.

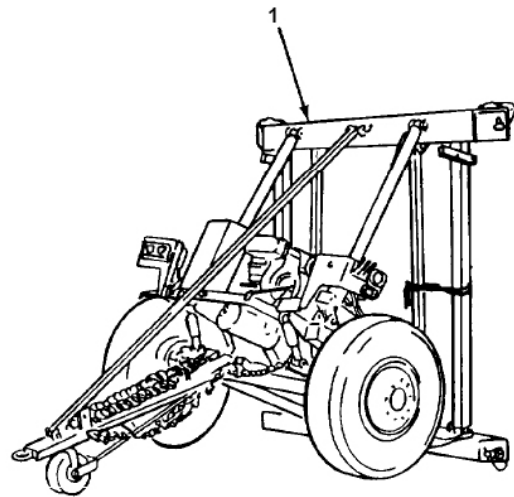

13. Install hitch pin (85) and safety pin (84) and lock pivoting tray lockout brace (86) on lower bracket (87).

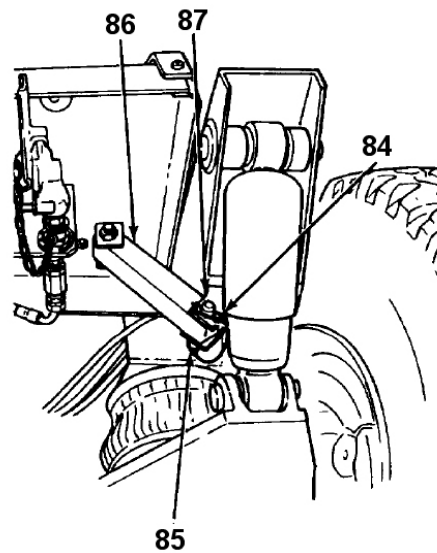

By Order of the Secretary of the Army:

PETER J. SCHOOMAKER
General, United States Army
Chief of Staff

Official:

SANDRA R. RILEY
Administrative Assistant to the
Secretary of the Army
0522002

Distribution:

To be distributed in accordance with the initial distribution number (IDN) 391052,
requirements for MWO 9-2330-390-25-1.

RECOMMENDED CHANGES TO PUBLICATIONS AND BLANK FORMS	Use Part II (reverse) for Repair Parts and Special Tools Lists (RPSTL) and Supply Catalogs/Supply Manuals SC/SM).	Date
For use of this form, see AR 25-30; the proponent agency is ODISC4.		
TO: (Forward to proponent of publication or form) (Include ZIP Code)		FROM: (Activity and location) (include ZIP code)

PART I – ALL PUBLICATIONS (EXCEPT RPSTL AND SC/SM) AND BLANK FORMS

PUBLICATION/FORM NUMBER MWO 9-2330-390-25-1	DATE 17 OCT 2005	TITLE POSITIONING TUBE
---	----------------------------	----------------------------------

ITEM	PAGE	PARA	LINE	FIGURE NO.	TABLE	RECOMMENDED CHANGES AND REASON
0052 00-4						Inspection Step 1 WP reference should be (WP 0003 00) <div style="text-align: center; font-size: 4em; opacity: 0.5;"> SAMPLE </div>

**Reference to line numbers within the paragraph or subparagraph.*

TYPED, GRADE OR TITLE	TELEPHONE EXCHANGE/AUTOVON, PLUS EXTENSION	SIGNATURE
-----------------------	--	-----------

TO: (Forward direct to addressee listed in publication)	FROM: (Activity and location) (Include Zip Code)	Date
--	---	-------------

PART II – REPAIR PARTS AND SPECIAL TOOL LISTS AND SUPPLY CATALOGS/SUPPLY MANUALS

PUBLICATION NUMBER MWO 9-2330-390-25-1	DATE 17 OCT 2005	Unit, Direct Support and General Support Maintenance Repair Parts and Special Tools List
--	----------------------------	--

PAGE NO.	COLM NO.	LINE NO.	NATIONAL STOCK NUMBER	REFERENCE NO.	FIGURE NO.	ITEM NO.	TOTAL NO. OF MAJOR ITEMS SUPPORTED	RECOMMENDED ACTION

PART III – REMARKS *(Any general remarks, comments or suggestions for improvement of work forms. Additional blank sheets may be added as space needed).*

SAMPLE

TYPED, GRADE OR TITLE	TELEPHONE EXCHANGE/AUTOVON, PLUS EXTENSION	SIGNATURE
-----------------------	--	-----------

TO: <i>(Forward direct to addressee listed in publication)</i>	FROM: <i>(Activity and location) (Include ZIP Code)</i>	DATE
---	--	-------------

PART II - REPAIR PARTS AND SPECIAL TOOL LISTS AND SUPPLY CATALOGS/SUPPLY MANUALS

PUBLICATION NUMBER MWO 9-2330-390-25-1	DATE 17 OCT 2005	TITLE POSITIONING TUBE
--	----------------------------	----------------------------------

PAGE NO.	COLM NO.	LINE NO.	NATIONAL STOCK NUMBER	REFERENCE NO.	FIGURE NO.	ITEM NO.	TOTAL NO. OF MAJOR ITEMS SUPPORTED	RECOMMENDED ACTION

PART III - REMARKS *(Any general remarks or recommendations, or suggestions for improvement of publications and blank forms. Additional blank sheets may be used if more space is needed.)*

TYPED NAME, GRADE OR TITLE	TELEPHONE EXCHANGE/AUTOVON, PLUS EXTENSION	SIGNATURE
----------------------------	--	-----------

<p>RECOMMENDED CHANGES TO PUBLICATIONS AND BLANK FORMS</p> <p>For use of this form, see AR 25-30; the proponent agency is OAASA</p>	<p>Use Part II (<i>reverse</i>) for Repair Parts and Special Tool Lists (RPSTL) and Supply Catalogs/Supply Manuals (SC/SM).</p>	<p>DATE</p>
--	---	-------------

<p>TO: (<i>Forward to proponent of publication or form</i>) (<i>Include ZIP Code</i>)</p>	<p>FROM: (<i>Activity and location</i>) (<i>Include ZIP Code</i>)</p>
---	---

PART I - ALL PUBLICATIONS (EXCEPT RPSTL AND SC/SM) AND BLANK FORMS

<p>PUBLICATION/FORM NUMBER MWO 9-2330-390-25-1</p>	<p>DATE 17 OCT 2005</p>	<p>TITLE POSITIONING TUBE</p>
--	-----------------------------	-----------------------------------

ITEM	PAGE	PARA-	LINE	FIGURE NO.	TABLE	RECOMMENDED CHANGES AND REASON

** Reference to line numbers within the paragraph or subparagraph.*

<p>TYPED NAME, GRADE OR TITLE</p>	<p>TELEPHONE EXCHANGE/AUTOVON, PLUS EXTENSION</p>	<p>SIGNATURE</p>
-----------------------------------	---	------------------

TO: <i>(Forward direct to addressee listed in publication)</i>	FROM: <i>(Activity and location) (Include ZIP Code)</i>	DATE
---	--	-------------

PART II - REPAIR PARTS AND SPECIAL TOOL LISTS AND SUPPLY CATALOGS/SUPPLY MANUALS

PUBLICATION NUMBER MWO 9-2330-390-25-1	DATE 17 OCT 2005	TITLE POSITIONING TUBE
--	----------------------------	----------------------------------

PAGE NO.	COLM NO.	LINE NO.	NATIONAL STOCK NUMBER	REFERENCE NO.	FIGURE NO.	ITEM NO.	TOTAL NO. OF MAJOR ITEMS SUPPORTED	RECOMMENDED ACTION

PART III - REMARKS *(Any general remarks or recommendations, or suggestions for improvement of publications and blank forms. Additional blank sheets may be used if more space is needed.)*

TYPED NAME, GRADE OR TITLE	TELEPHONE EXCHANGE/AUTOVON, PLUS EXTENSION	SIGNATURE
----------------------------	--	-----------

